

# KTR-SI Overload systems

## Flange type



For legend of pictogram please refer to flapper on the cover



Type FT

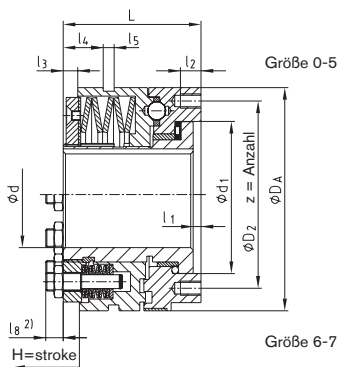

Type KT

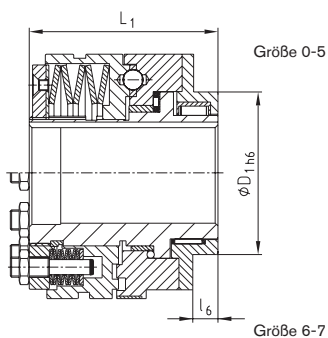

Type LT

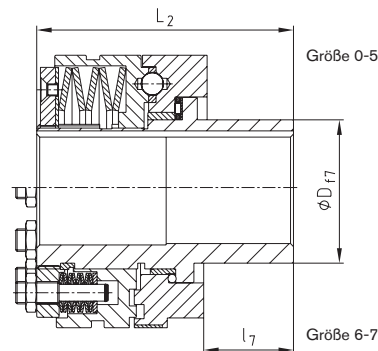

### Technical data

Size	Torques [Nm]												Weight with max. bore [kg]
	Type DK				Type SR and SGR				Type FR				
	T1	T2	T3	T4	T1	T2	T3	T4	T1	T2	T3	n <sub>max.</sub> [rpm] <sup>3)</sup>	
0	2,5-5	5-20	-	20-40	5-10	10-40	-	-	5-10	10-20	20-40	6000	0,41
1	6-12	12-25	25-55	55-100	12-25	25-50	50-100	-	12-25	25-50	50-100	5000	1,30
2	12-25	25-50	50-120	120-200	25-50	50-100	100-200	-	25-50	50-100	100-200	4000	2,27
3	25-50	50-100	100-250	200-450	50-100	100-200	200-450	-	50-100	100-200	200-450	3500	3,88
4	50-100	100-200	200-500	500-1000	100-200	200-400	400-800	800-2000	100-200	200-400	400-800	3000	8,34
5	85-250	230-600	300-1000	600-2000	170-450	350-900	600-1800	1200-3400	170-450	350-900	600-1800	2300	13,51
6	180-480	360-960	720-1950	1600-3300	300-750	600-1500	1200-3000	2900-5800	-	-	-	-	21
7	250-520	500-1050	1000-2100	2000-3600	550-1100	1100-2200	2200-4400	3000-8200	-	-	-	-	37

### Dimensions [mm]

Size	Bore d		d <sub>1</sub>	D	D <sub>1</sub>	D <sub>2</sub>	D <sub>A</sub>	l <sub>1</sub>	l <sub>2</sub>	l <sub>3</sub>	l <sub>4</sub>	l <sub>5</sub>	l <sub>6</sub>	l <sub>7</sub>	L	L <sub>1</sub>	L <sub>2</sub>	z	H=stroke			
	pilot b.	max.																	DK	SR	SGR	FR
0	7	20	41,0	28	38	48	55	4,0	6,5	3,0	7,5	9	8	27,5	38,5	51,0	66,0	6xM5	1,4	1,2	0,6	1,6
1	10	25	60,0	38	50	70	82	4,0	8,0	6,0	11,5	9	10	33,0	52,0	70,0	85,0	6xM5	2,3	1,8	0,8	2,3
2	14	35	78,0	52	60	89	100	5,0	10,0	5,0	12,0	9	12	39,0	61,0	78,0	100,0	6xM6	2,4	2,0	1,1	3,0
3	18	45	90,5	65	80	105	120	5,0	12,0	8,5	21,0	10	12	47,0	78,0	96,0	125,0	6xM8	2,7	2,2	1,2	3,5
4	24	55	105,0	78	100	125	146	6,5	15,0	11,0	27,0	9	16	52,5	100,0	124,5	152,5	6xM10 <sup>1)</sup>	3,7	2,5	1,2	3,8
5	30	65	120,5	90	120	155	176	6,5	17,0	12,0	33,0	9	18	57,5	113,5	140,0	171,0	6xM12 <sup>1)</sup>	4,6	3,0	1,6	4,5
6 <sup>2)</sup>	40	80	136,0	108	130	160	200	7,0	20,0	14,0	39,0	9	20	64,0	119,0	150,0	183,0	6xM12 <sup>1)</sup>	5,0	3,5	2,5	-
7 <sup>2)</sup>	50	100	168,0	135	160	200	240	8,0	25,0	15,0	46,0	9	25	72,0	141,0	175,0	213,0	6xM16 <sup>1)</sup>	5,5	4,0	2,7	-

<sup>1)</sup> Type T4 SR and SRG: tightening torques according to 12.9  
<sup>2)</sup> Size 6: dimension l<sub>8</sub> = 15 mm, size 7: dimension l<sub>8</sub> = 21 mm  
<sup>3)</sup> See comments on page 230

Ordering example:

KTR-SI 2	FR	FT	T2	d Ø20	40 Nm
Type / size	Type [DK/SR/SGR]	Type	Disk spring layer	Bore	Torque set