

RADEX®-N NANA 3

Steel lamina couplings

Pump drives according to API 610

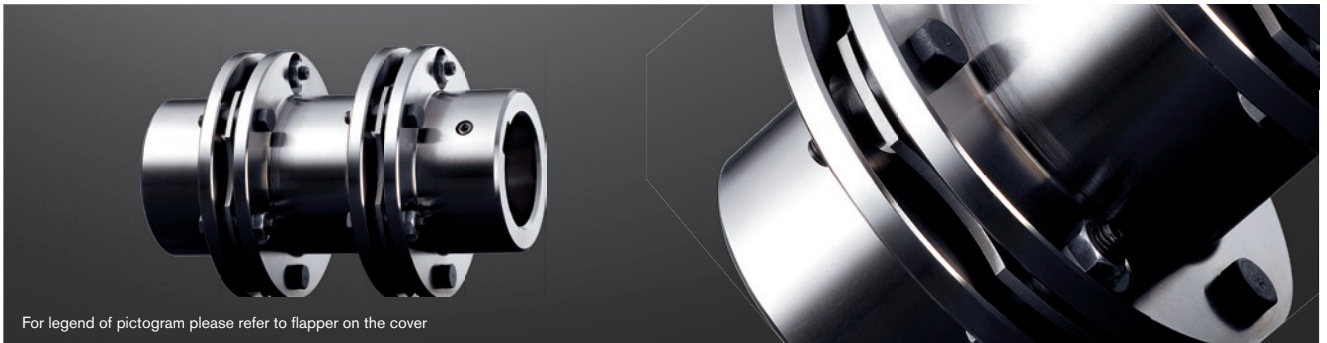

For legend of pictogram please refer to flapper on the cover

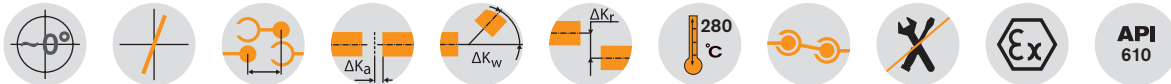

RADEX®-N Type NANA 3							
Size	Max. finish bore	Dimensions [mm]				Perm. displacements	
	d	D	DA	EStandard ¹⁾	l _{1/2}	Angle [°] each lamina	Axial [mm]
42	42	68	104	100	45	1,0	2,8
50	50	78	126	140/180	55	1,0	3,2
60	60	88	138	100/140/180/250	55	1,0	2,0
70	70	102	156	100/140/180	65	1,0	2,2
80	80	117	179	100/140/180/250	75	1,0	2,6
85	85	123	191	100/140/180/250	80	1,0	2,3
90	90	132	210	140/180/250	80	1,0	2,0
105	105	147	225	250	90	1,0	2,4
115	115	163	265	250	100	1,0	2,8
135	135	184	305	250	135	1,0	3,5
136	135	180	300		135	0,7	3,7
156	150	195	325		150	0,7	4,2
166	165	225	350		165	0,7	4,5
186	180	250	380		185	0,7	4,8
206	200	275	420		200	0,7	5,2
246	240	320	500		240	0,7	6,0
286	280	383	567		280	0,7	6,7
336	330	445	660	acc. to customer's specifications	330	0,7	7,5
138	135	180	300		135	0,5	2,6
158	150	195	325		150	0,5	2,8
168	165	225	350		165	0,5	3,0
188	180	250	380		185	0,5	3,2
208	200	275	420		200	0,5	3,5
248	240	320	500		240	0,5	4,0
288	280	383	567		280	0,5	4,5
338	330	445	660		330	0,5	5,0

¹⁾ Other distance dimensions E available on request.

Ordering example:	RADEX®-N 60	NANA 3	Ø50	Ø60	140
	Coupling size	Type	Finish bore d ₁	Finish bore d ₂	Shaft distance dimension

Components

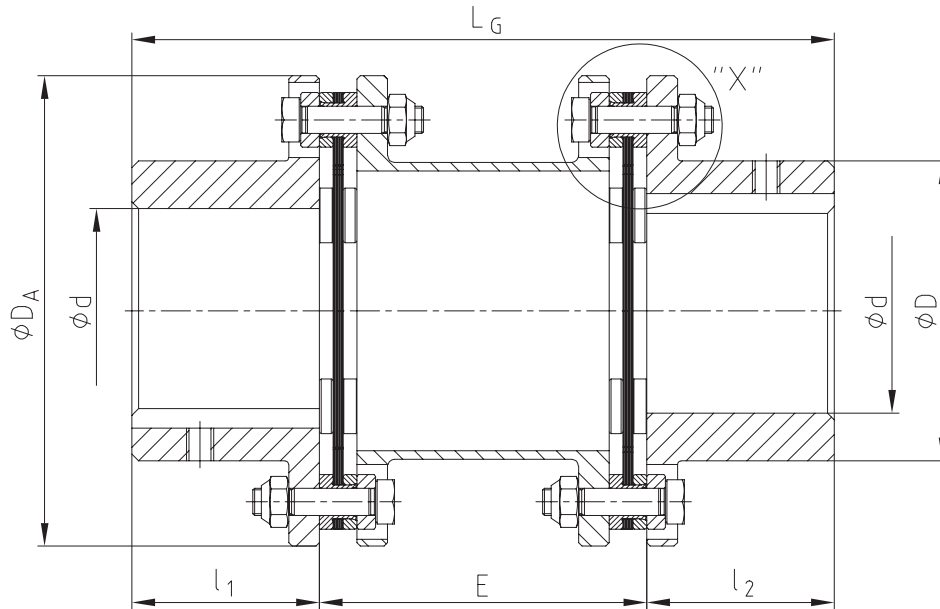

Detail "X"

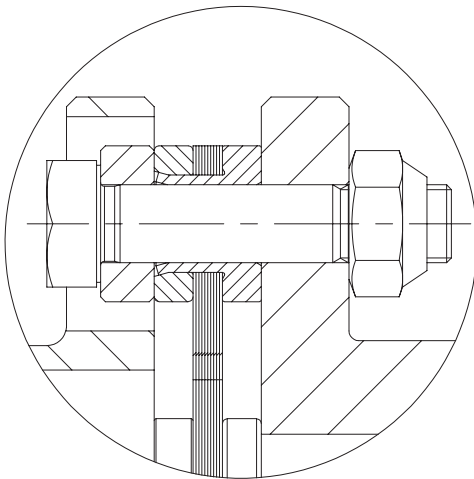

Safety gear of the spacer:
The lamina sets have a sleeve in order to secure the spacer if the lamina breaks.