

TOOLFLEX® PI

Metal bellow-type couplings

Axial plug-in

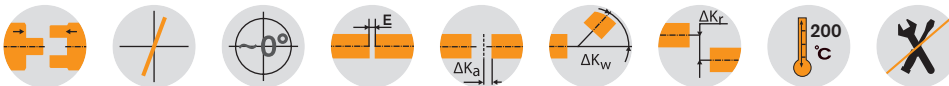

TOOLFLEX® Type S-PI Hub material aluminium/bellow stainless steel

Size	Type	Dimensions [mm]													
		General									Clamping screw				
		min. d ₁ ; d ₂	max. d ₁	max. d ₂	L ¹⁾	l ₁	l ₂	E	D _H	H	M ₁ ; M ₂	D ₃	e	t ₁ ; t ₂	T _A [Nm]
20	S	8	20	20	67,0	21,5	33,5	19,0	40	0,5 - 1	M5	43,5	14,5	6	6
30	S	10	30	28	73,5	23,0	33,5	26,0	55	0,5 - 1	M6	58,0	19,0	7	10
38	S	12	38	32	87,5	25,5	44,0	30,0	65	0,5 - 1,5	M8	72,6	25,0	9	25
42	S	14	42	35	93,0	30	39,0	35,0	70	0,5 - 1,5	M8	76,1	25,0	9	25
45	S	14	45	42	96,0	32,0	41,5	39,0	83	0,5 - 1,5	M10	89,0	30,0	11	49
55	S	20	55	55	130,0	40	58,5	31	100	0,5 - 1,5	M12	106,0	37	14	120

Technical data of TOOLFLEX® S-PI

Size	Type	Torque of bellow T _{KN} [Nm] ²⁾	Max. speed n [rpm]	Moment of inertia ⁴⁾ [x10 ⁻⁶ kgm ²]	Torsion spring stiffness C _T [Nm/rad]	Axial spring stiffness [N/mm]	Radial spring stiffness [N/mm]	Perm. displacements		Weight ³⁾ [kg]
								Radial [mm]	Angular [degrees]	
20	S	15	11950	37	6600	63	189	0,15	1,0	0,15
30	S	35	8700	140	11500	97	233	0,20	1,5	0,29
38	S	65	7350	329	21500	108	318	0,20	1,5	0,50
42	S	95	6820	396	31500	120	499	0,20	1,5	0,49
45	S	170	5750	1031	55000	132	738	0,25	1,5	0,93
55	S	340	4800	6150	144100	160	894	0,25	1,5	3,80

TOOLFLEX® Type M-PI Hub material aluminium/bellow stainless steel

Size	Type	Dimensions [mm]													
		General									Clamping screw				
		min. d ₁ ; d ₂	max. d ₁	max. d ₂	L ¹⁾	l ₁	l ₂	E	D _H	H	M ₁ ; M ₂	D ₃	e	t ₁ ; t ₂	T _A [Nm]
20	M	8	20	20	74,0	21,5	33,5	19,0	40	0,5 - 1	M5	43,5	14,5	6	6
30	M	10	30	28	82,5	23,0	33,5	26,0	55	0,5 - 1	M6	58,0	19,0	7	10
38	M	12	38	32	99,5	25,5	44,0	30,0	65	0,5 - 1,5	M8	72,6	25,0	9	25
42	M	14	42	35	104,0	30	39,0	35,0	70	0,5 - 1,5	M8	76,1	25,0	9	25
45	M	14	45	42	112,5	32,0	41,5	39,0	83	0,5 - 1,5	M10	89,0	30,0	11	49
55	M	20	55	55	143,5	40	58,5	45	100	0,5 - 1,5	M12	106,0	37	14	120

Technical data of TOOLFLEX® M-PI

Size	Type	Torque of bellow T _{KN} [Nm] ²⁾	Max. speed n [rpm]	Moment of inertia ⁴⁾ [x10 ⁻⁶ kgm ²]	Torsion spring stiffness C _T [Nm/rad]	Axial spring stiffness [N/mm]	Radial spring stiffness [N/mm]	Perm. displacements		Weight ³⁾ [kg]
								Radial [mm]	Angular [degrees]	
20	M	15	11950	38	4900	42	126	0,20	1,5	0,16
30	M	35	8700	145	10200	65	155	0,25	2,0	0,31
38	M	65	7350	346	15100	72	212	0,25	2,0	0,52
42	M	95	6820	427	22000	80	333	0,25	2,0	0,52
45	M	170	5750	1127	41000	88	492	0,30	2,0	1,00
55	M	340	4800	6270	96100	107	598	0,30	2,0	3,90

¹⁾ When being plugged in

²⁾ For selection see page 18 et seqq.

³⁾ Figures refer to the complete coupling with max. bores

Review of shaft-hub-connection: Friction torques for hub type 2.5 for Ød₁/Ød₂

Size	Ø8	Ø9	Ø10	Ø11	Ø12	Ø14	Ø15	Ø16	Ø18	Ø19	Ø20	Ø24	Ø25	Ø28	Ø30	Ø32	Ø35	Ø38	Ø40	Ø42
20	17,6	18,1	18,6	19,1	19,5	20,5	21,0	21,4	22,4	22,9	23,3									
30				33,1	33,8	35,1	35,8	36,5	37,8	38,5	39,2	41,9	42,5	44,6	45,9					
38					79,2	80,4	81,7	84,2	85,4	86,6	91,6	92,8	96,5	99,0	102					
42					79,2	80,4	81,7	84,2	85,4	86,6	91,6	92,8	96,5	99,0	102	105				
45										157	165	167	173	177	181	187	193	197	200	
55											397	401	413	421	429	442	454	462	470	

Bestell- beispiel:	TOOLFLEX® 30 S-PI	d ₁ - Ø22	d ₂ - Ø18
	Size and type of coupling	Finish bore	Finish bore

TOOLFLEX® S-PI

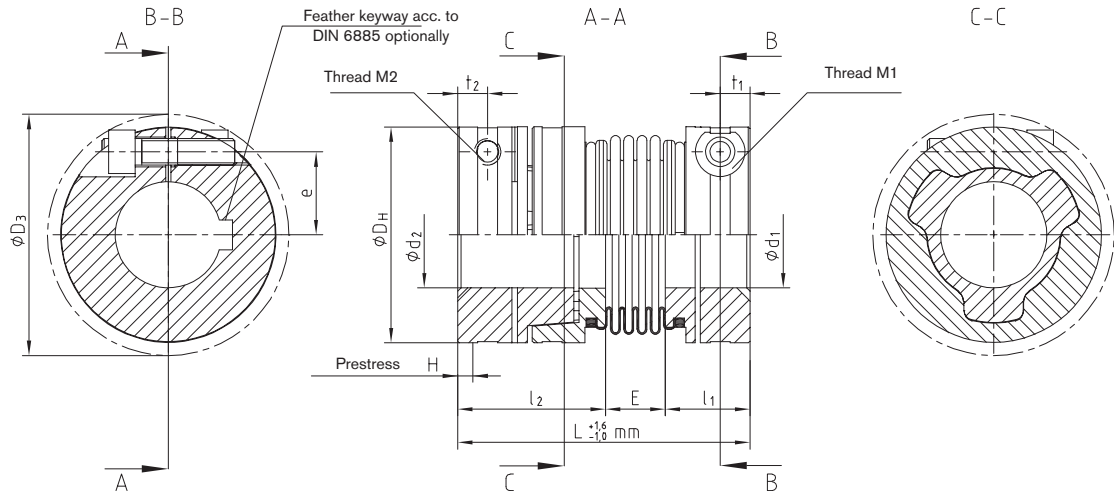

ROTEX® GS

Backlash-free
servo couplings

TOOLFLEX®

TOOLFLEX® M-PI

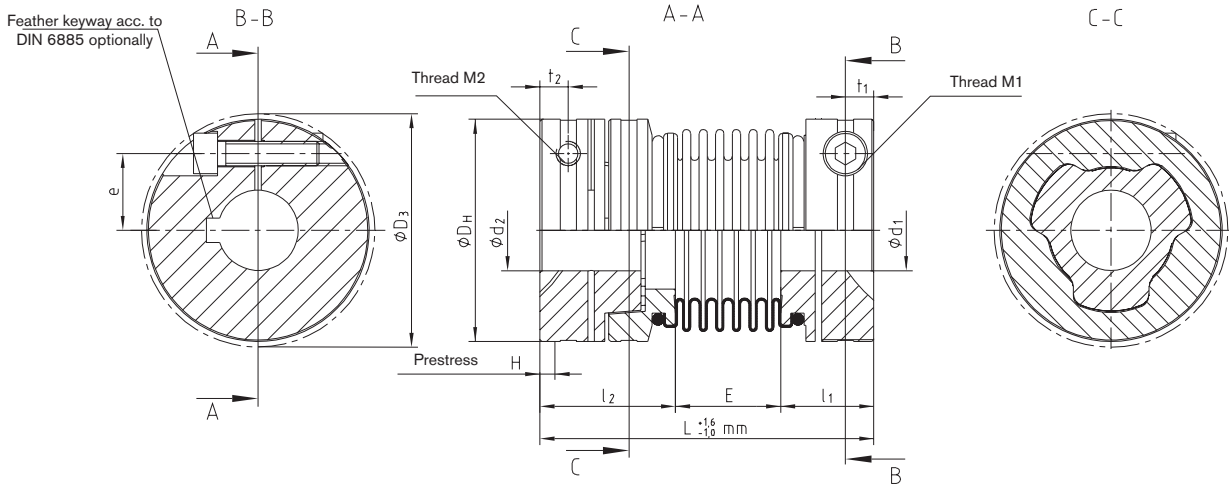

RADEX®-NC

COUNTEX®