

ROTEX® GS

Backlash-free jaw couplings

Standard types



For legend of pictogram please refer to flapper on the cover

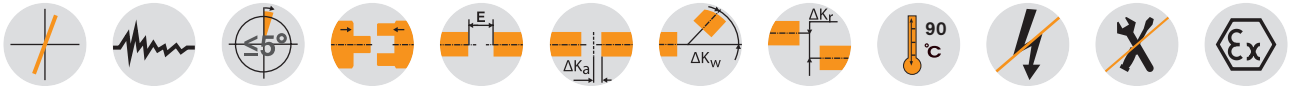

ROTEX® GS 5 - 38

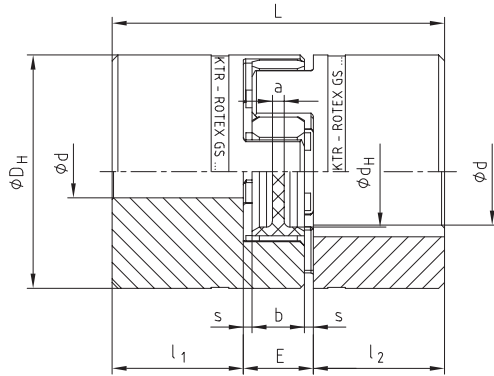

ROTEX® GS 42 - 90

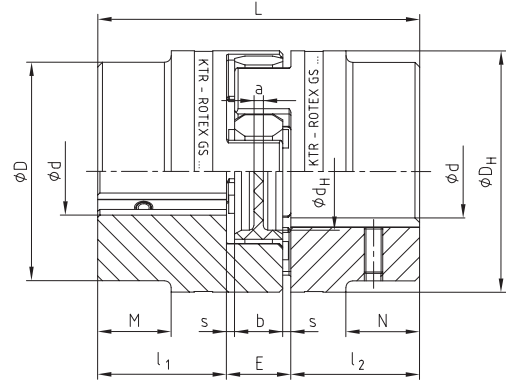

Hub types:

Type 1.0

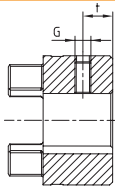

with keyway
and set screw

Type 1.1

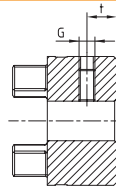

without keyway and with
set screw

Type 1.2

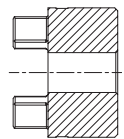

without keyway and
without set screw

ROTEX® GS standard types For size 5 to 38 hub material aluminium/for size 42 to 90 hub material steel

Size	Spider torque T _{KN} [Nm] for 98Sh-A ¹⁾	Maximum finish bore Ød for hub type			Dimensions [mm]										Setscrew DIN EN ISO 4029 hub type 1.0/1.1		
		1.0	1.1	1.2	D	D _H	d _H	L	l ₁ :l ₂	M:N	E	b	s	a	G	t	T _A
5	0,9	-	6	5	-	10	-	15	5	-	5	4	0,5	4,0	M2	2,5	0,2
7	2,0	7	7	7	-	14	-	22	7	-	8	6	1,0	6,0	M3	3,5	0,3
9	5,0	10	11	11	-	20	7,2	30	10	-	10	8	1,0	1,5	M4	5,0	1,5
12	9,0	12	12	12	-	25	8,5	34	11	-	12	10	1,0	3,5	M4	5,0	1,5
14	12,5	16	16	16	-	30	10,5	35	11	-	13	10	1,5	2,0	M4	5,0	1,5
19	21	24	-	-	-	40	18	66	25	-	16	12	2,0	3,0	M5	10	2,0
24	60	28	-	-	-	55	27	78	30	-	18	14	2,0	3,0	M5	10	2,0
28	160	38	-	-	-	65	30	90	35	-	20	15	2,5	4,0	M8	15	10
38	325	45	-	-	-	80	38	114	45	-	24	18	3,0	4,0	M8	15	10
42	450	55	-	-	85	95	46	126	50	28	26	20	3,0	4,0	M8	20	10
48	525	62	-	-	95	105	51	140	56	32	28	21	3,5	4,0	M8	20	10
55	685	74	-	-	110	120	60	160	65	37	30	22	4,0	4,5	M10	20	17
65	940	80	-	-	115	135	68	185	75	47	35	26	4,5	4,5	M10	20	17
75	1920	95	-	-	135	160	80	210	85	53	40	30	5,0	5,0	M10	25	17
90	3600	110	-	-	160	200	104	245	100	62	45	34	5,5	6,5	M12	30	40

¹⁾ Other spiders/selection see page 18/19

Ordering example:	ROTEX® GS 24	98 Sh-A-GS	d20	2.5 - Ø 24		1.0 - Ø 20	
	Coupling size	Spider hardness	Optional: Bore in spider	Hub type	Finish bore	Hub type	Finish bore

Hub types:

Type 2.0
Type 2.1

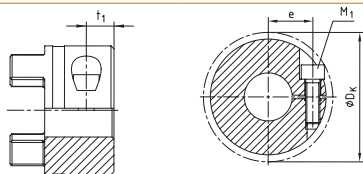

size 5 to 14
Type 2.0: Single slotted clamping hub without feather keyway (only for ATEX cat. 3), torque depending on bore Ø.
Type 2.1: single slotted clamping hub with feather keyway

Type 2.5
Type 2.6

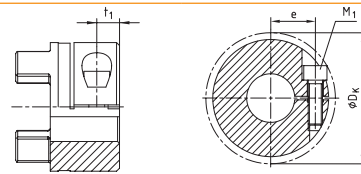

from size 19
Type 2.5: double slotted clamping hub without feather keyway (only for ATEX cat. 3), torque depending on bore Ø.
Type 2.6: double slotted clamping hub with feather keyway

ROTEX® GS standard types For size 5 to 38 hub material aluminium/for size 42 to 90 hub material steel

Size	Spider torque T _{KN} [Nm] for 98Sh-A ¹⁾	Maximum finish bore Ød for hub type				Dimensions [mm]													Clamping screw DIN EN ISO 4762 (ROTEX® 5 DIN 84) hub type 2.0/2.1/2.5/2.6				
		2.0	2.1	2.5	2.6	D	D _H	d _H	L	l _{1,2}	M;N	E	b	s	a	M ₁	t ₁	e	D _K	T _A [Nm]			
5	0,9	5	5	-	-	-	10	-	15	5	-	5	4	0,5	4,0	M1,2	2,5	3,5	11,4	- ²⁾			
7	2,0	7	7	-	-	-	14	-	22	7	-	8	6	1,0	6,0	M2	3,5	5,0	16,5	0,37			
9	5,0	11	11	-	-	-	20	7,2	30	10	-	10	8	1,0	1,5	M2,5	5,0	7,5	23,4	0,76			
12	9,0	12	12	-	-	-	25	8,5	34	11	-	12	10	1,0	3,5	M3	5,0	9,0	27,5	1,34			
14	12,5	16	16	-	-	-	30	10,5	35	11	-	13	10	1,5	2,0	M3	5,0	11,5	32,2	1,34			
19	21	-	-	24	24	-	40	18	66	25	-	16	12	2,0	3,0	M6	11,0	14,5	46	10,5			
24	60	-	-	28	28	-	55	27	78	30	-	18	14	2,0	3,0	M6	10,5	20,0	57,5	10,5			
28	160	-	-	38	38	-	65	30	90	35	-	20	15	2,5	4,0	M8	11,5	25,0	73	25			
38	325	-	-	45	45	-	80	38	114	45	-	24	18	3,0	4,0	M8	15,5	30,0	83,5	25			
42	450	-	-	50	45	85	95	46	126	50	28	26	20	3,0	4,0	M10	18	32,0	93,5	69			
48	525	-	-	55	55	95	105	51	140	56	32	28	21	3,5	4,0	M12	21	36,0	105	120			
55	685	-	-	68	68 ³⁾	110	120	60	160	65	37	30	22	4,0	4,5	M12	26	42,5	119,5	120			
65	940	-	-	70	70 ³⁾	115	135	68	185	75	47	35	26	4,5	4,5	M12	33	45,0	124	120			
75	1920	-	-	80	80	135	160	80	210	85	53	40	30	5,0	5,0	M16	36	51,0	147,5	295			
90	3600	-	-	90	90	160	200	104	245	100	62	45	34	5,5	6,5	M20	40	60,0	192	580			

¹⁾ Other spiders/selection see page 18 et seqq.

²⁾ No T_A defined (slotted screw)

³⁾ From Ø60 keyway opposite to the clamping screw

⁴⁾ Clamping hub single slotted with 2-off clamping screws M4 and dimension e=15

Review of shaft-hub-connection: Friction torques for hub type 2.0

Size	Ø2	Ø3	Ø4	Ø5	Ø6	Ø7	Ø8	Ø9	Ø10	Ø11	Ø12	Ø14	Ø15	Ø16
7		0,8	0,9	0,95	1,0	1,1								
9			2,1	2,2	2,3	2,4	2,5	2,6	2,7	2,8				
12			3,6	3,8	4,0	4,1	4,3	4,5	4,7	4,8	5,0			
14				4,7	4,8	5,0	5,1	5,3	5,5	5,6	5,8	6,1	6,3	6,5

Review of shaft-hub-connection: Friction torques for hub type 2.5

Size	Ø8	Ø10	Ø11	Ø14	Ø15	Ø16	Ø18	Ø19	Ø20	Ø22	Ø24	Ø25	Ø28	Ø30	Ø32	Ø35	Ø38	Ø40	Ø42	Ø45	Ø48	Ø50	Ø55	Ø60	Ø65	Ø70	Ø75	Ø80	Ø90
19	25	27	27	29	30	31	32	32	34	30 ⁴⁾	32 ⁴⁾																		
24		34	35	36	38	38	39	40	41	42	43	45	46																
28				80	81	81	84	85	87	89	91	92	97	99	102	105	109												
38				92	94	97	98	99	102	104	105	109	112	113	118	122	123	126	130										
42									232	238	244	246	255	260	266	274	283	288	294	301	309	315							
48												393	405	413	421	434	445	454	462	473	486	494	514						
55															473	486	498	507	514	526	539	547	567	587	608				
65															507	518	526	535	547	559	567	587	608	627	648				
75																		1102	1124	1148	1163	1201	1239	1278	1316	1354	1393		
90																		1944	1980	2016	2040	2100	2160	2220	2280	2340	2400	2520	