



## Innovative Power Transmission



**HYGUARD<sup>®</sup>**  
**Safety Couplings**  
*owner's choice*

# Safety Couplings and Clamping Elements

The main task of overload protection systems being installed in the drive of machineries is to safeguard valuable industrial goods against unexpected overload stresses. In spite of continuous modernization and technical advance of drive systems, the risk of such damages has not become less, but even bigger.

The reason for this is the growing pressure which competition is exerting on plant and machinery manufacturers, and the thereby resulting necessity to continuously optimize their products. Over-dimensioning of vital components is no longer deemed as necessary as it used to be in the past. Modern computer techniques offer all possibilities to design essential machinery components for permanent reliability while simultaneously meeting the requirements for lightweight construction.

In spite of all that, machinery failures due to suddenly occurring unexpected overload cannot be excluded completely. One single damage, however, may considerably exceed the costs for efficient overload protection.

Now as before, appropriate safety equipment is necessary to protect machinery. In the first place, safety couplings which are nowadays available in a variety of different versions and executions are used for this purpose in drive systems. However, not each of these couplings is suitable for every drive application in the same way. The decisive criterion is the sum of the factors which may contribute to the disturbance of the operation processes. Therefore, new applications often also require new safety systems.

The HYGUARD® safety coupling belongs to such protection systems. Contrary to the shear-pin coupling it works after a completely different operation principle.

The torque is transmitted by frictional engagement of the contact faces of shaft and hub. If the preset torque is not exceeded, it will work without slipping. If, however, the preset torque value will be surpassed, the hydrostatic pressure is released immediately, thus disconnecting the system. Re-commissioning is possible within shortest time, as the only thing to do is to set the system under pressure again.

Shear-pin couplings belong to the most well-known safety devices. They fulfil their safety function by cutting-off the bolts used for torque transmission at a predetermined nominal shear point as soon as the admissible torque has been exceeded. Extensive test programmes, some of which were carried out by scientific institutes, investigated the influence of various parameters on the shearing behaviour. The results

led to the optimization of the pin geometry, whereby the reliability of shear-pin couplings could be highly improved.

Since the function principle of such couplings is well known, they are not treated in more detail here. The reason for describing the HYGUARD® Safety Coupling is not only because its function is based on a different principle, but also because the actual safety element is well suitable for other interesting possibilities of application. One example is the possibility of radial and axial positioning of gear wheels, hubs, and other components on shafts or axis by means of the TORLOC® clamping elements working on the same principle.

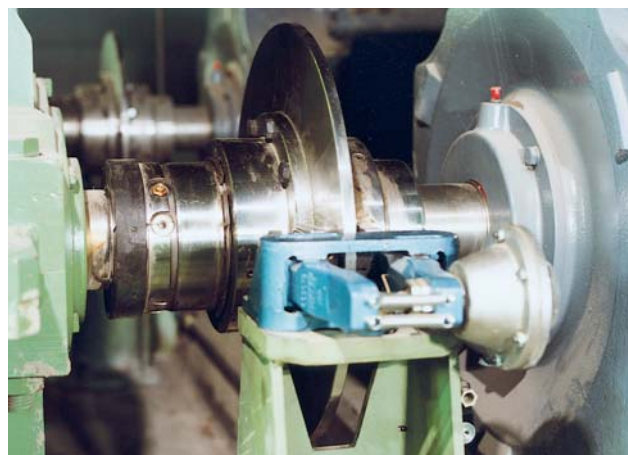

1

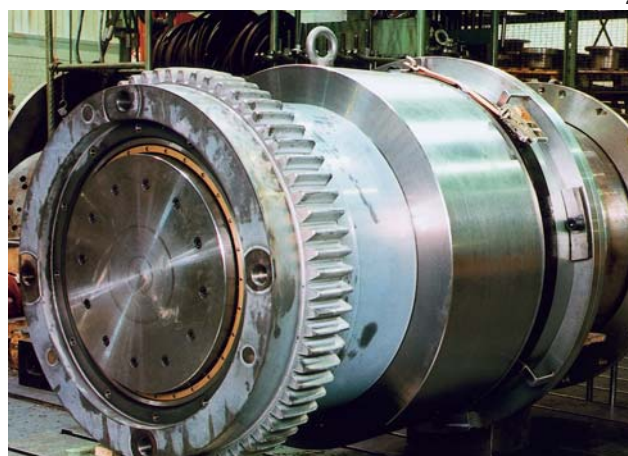

2

1 HYGUARD® Safety coupling/brake disk combination in a four-high stand, built-in between main motor and pinion stand gearbox.

2 Curved tooth coupling SBGk 560 with safety element HYGUARD® HDW 760.



1



2



3

1 Renk Tacke high-speed gearbox and HYGUARD® Safety Coupling in the machinery of a power unit test stand

2 Component of a power unit test stand with 3 HYGUARD® Safety Couplings in total

3 Safety element HDW 760, ready to be mounted into a curved tooth coupling.

## Table of Contents

	Type series	Page
Commissioning		6
Selection		7 – 8
Applications		9

Basic design	B	10
Basic design with roller bearings	BW	11
Option with integrated keyway	BN	12
Option with integrated keyway and roller bearings	BWN	13
Option with shaft part, bush and connecting flanges	BWL	14

Combinations of curved tooth coupling/ HYGUARD® Safety Coupling	SB/BW	15
	SBk/BW	16 – 17
	LBk/BW	18
	SBL/BWL	19
	SBLk/BWL	20
	LBLk/BWL	21

Curved tooth coupling in Shear pin design	HBBk	23
	SBBk	24
	SBBLk	25

TORLOC® Clamping Element	26
Special executions (examples)	27

Slip monitoring	28
Assembly accessories	29
Applications	30

# HYGUARD® Hydraulic Safety Couplings TORLOC® Hydraulic Clamping Elements



## HYGUARD® Safety Coupling

ensure a maximum of reliability. The combination of the HYGUARD® System with the proven curved tooth coupling works like a safety coupling with torque limitation. The release torque is adjustable and remains constant for the entire operation time. The reliable protection for valuable machinery.

Advantages of HYGUARD® Safety Couplings:

- Transmission of high torques within little space
- Torsionally rigid – flexible connection of shafts
- Overload protection with adjustable torque limitation
- Constant release torque over the entire duration of operation
- No interruption of operation due to material fatigue
- Low down-time costs
- Quick re-commissioning
- No cost-intensive stocking of spare parts

Basically, the HYGUARD® element integrated into the coupling, consists of two bushes being inserted into each other, both ends of which are closed in pressure-tight manner. The little gap between both parts is filled with hydraulic oil through the valve bore, and then pressurized. This leads to an expansion of the diameter. Built-in between shaft and hub this system acts as a clamping bush. Torque is transmitted by frictional engagement between the contact faces. The amount of transmittable torque is determined by the oil pressure in the ring gap. This pressure is adjustable, and thus, the torque, too.

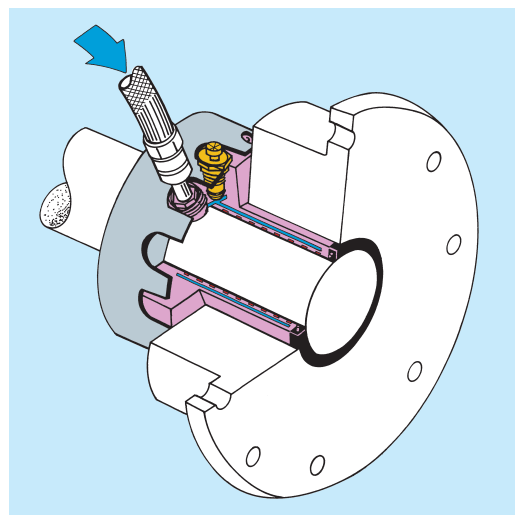
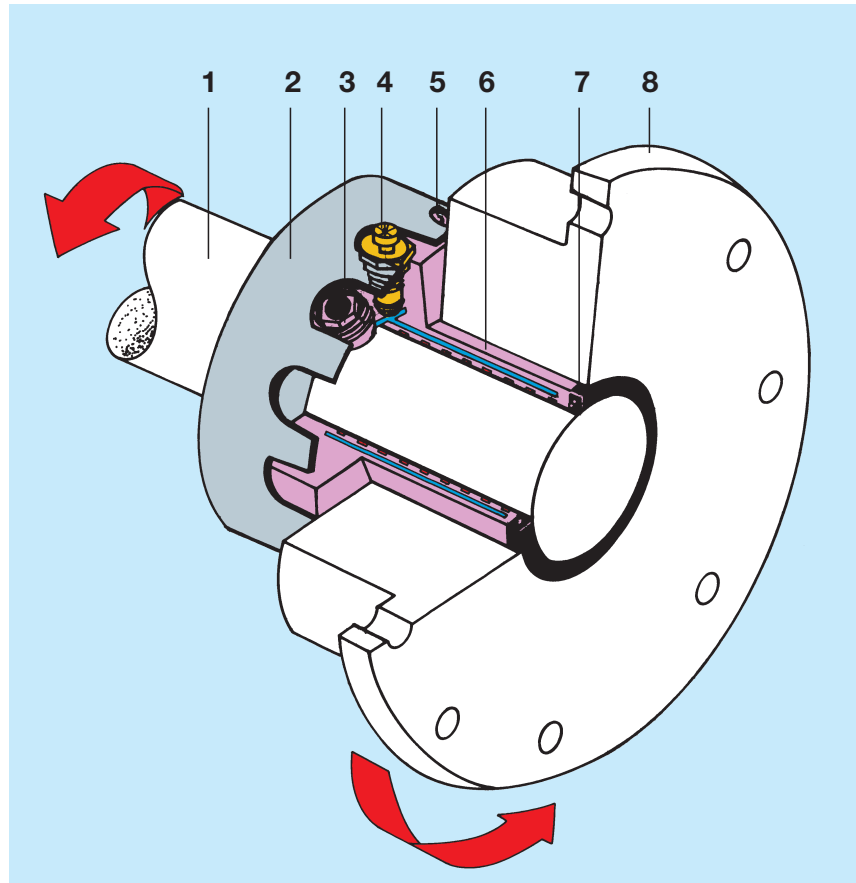

### Components of the HYGUARD® Safety Coupling:

- 1 Shaft
- 2 Shear ring
- 3 Injector connection
- 4 Shear tube
- 5 Screw plug for lubricant filling
- 6 Double-walled clamping element
- 7 Seal for lubricant filling
- 8 Coupling hub, gear wheel, or other driving element



### Protection owing to rapidness

is given by the safety disconnection, the essential components of which are the shear ring and the shear tube. There is a firm connection between shear ring and shaft, whereas the shear tube is accommodated in the movable part. If the operating torque exceeds the preset value, the safety element will slip on the profiled surfaces and the shear ring cuts off the top of the shear-tube. The system is depressurized within milliseconds and the connection is released.

### Re-commissioning

The HYGUARD® Safety Coupling is easy to activate again. A high-pressure pump with pressure gauge for pressure setting and hydraulic oil will be sufficient to put it into operation. The pump is connected to the injector, and with open shear tube the hydraulic oil is being pressed into the ring gap. If the pre-determined pressure required for the torque transmission has been reached, the shear tube will be closed.

The pressure chamber is now sealed hermetically, and the working pressure remains constant. The coupling is ready for use. Down-times are thus reduced to a minimum.

If the system has been disconnected due to overload, the shear tube is the only item to replace. Thereafter, the system is put into operation again as described above. The time-consuming replacement of shear pins or similar parts and their storage are thus omitted. Stockkeeping of spare parts is limited to some shear tubes, only.

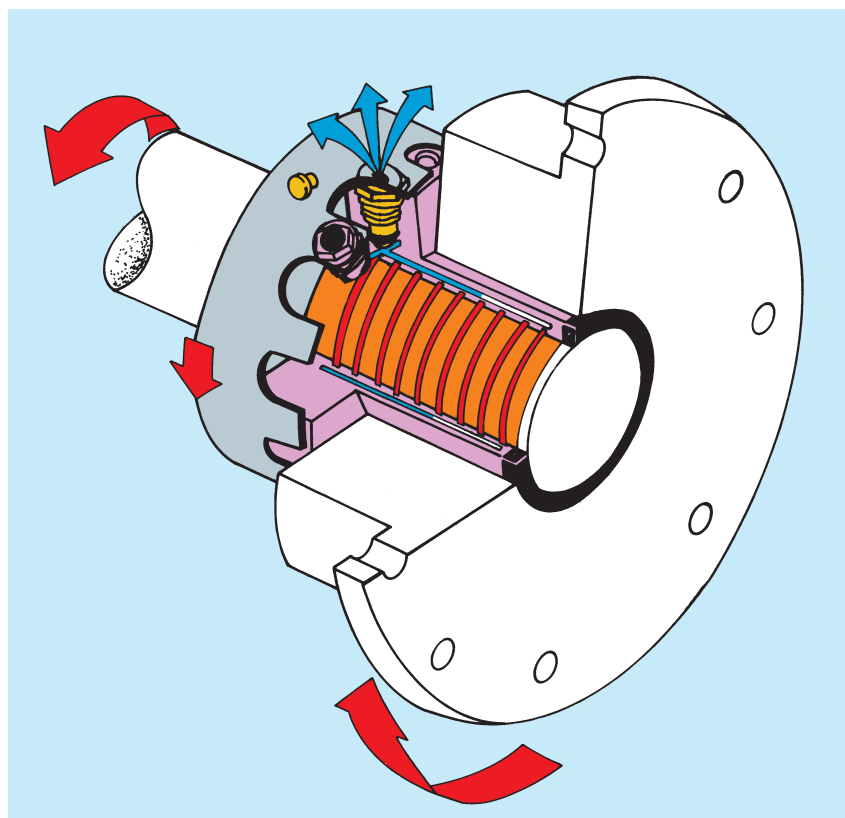

### Application Ranges

Due to the versatility of the HYGUARD® Safety Couplings and TORLOC® clamping elements, they are most suitable for many application fields, even under severest conditions. In rolling mills, e.g. where conventional couplings with shear pins or similar protection elements have previously been used, this safety system has been able to contribute to substantial cost savings.

All machines which may be subjected to overload or lock-ups count to the preferred ranges of application, e.g. in longitudinal shafts of paper mills, drafting equipment in the fibre industries, circular clamps of all kinds or solid pumps. The safety coupling becomes controllable in combination with differential speed monitoring. This equipment releases an alarm, or disengages automatically, if the coupling has been released due to overload, leading to differing speeds between shaft and hub.

### TORLOC® Clamping Elements

Wherever quick and safe tensioning of machinery parts is of vital importance, the TORLOC® clamping element is offering itself. In test stands it is used as quick-grip coupling, and in machine tools and production machinery it is used as clamping element with fine adjustment possibility.

The great advantages of this coupling when being used as quick grip coupling are the easy handling as well as the fact that the coupling is put back into service again within shortest time. Both, manual release by opening the valve as well as controlled remote release is possible. For this purpose, special safety valves with extended shear tubes are available.

In case of non-rotating clamped connections, remote release can be effected by means of high-pressure pipes and special valves.

# Recommissioning after Release



1 Remove old shear tube.



4 Connect pump, loosen shear tube by 1/4 turn.



2 Screw-in new shear tube and tighten it firmly.



5 Pump up until required pressure is reached, re-tighten shear tube firmly.



3 Remove sealing plug from injector connection.



6 Relief pressure in pump and disconnect the same. Insert sealing plug into injector connection.

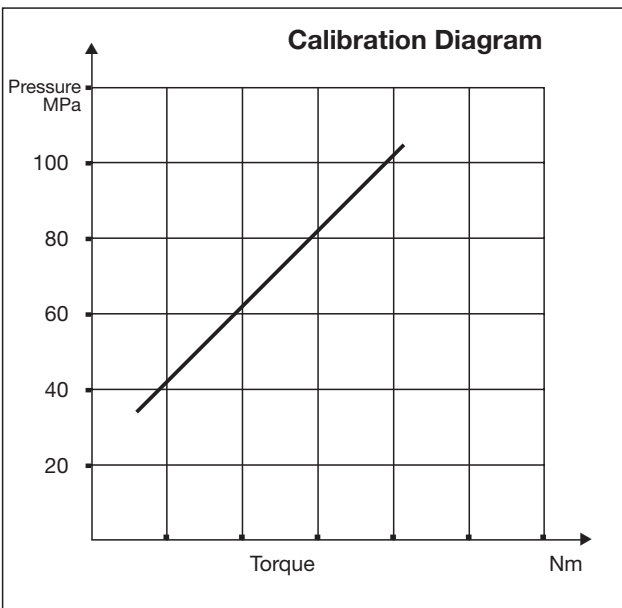

# Selection



## Selection

The size of the HYGUARD® safety coupling must be chosen primarily according to the peak torque to be transmitted. For selection of the design, the dimensions of the machine parts to be connected and the application itself are of importance. It is essential to pay attention to the following recommendations to achieve a safe and reliable design.

## Torque

For the various designs, each coupling size indicated in the selection tables is assigned a torque range which can be considered the optimum application range. Values outside of these limits may also be permissible depending on the application involved. Please consult us in such cases. As a rule, however, the release torque shall be within this range. Normally, a coupling is selected with a maximum permissible torque of approximately 1.5 times to twice the amount of operating torque to be transmitted. In rotating drive applications, a shock factor must also be taken into account. This factor depends on the driving machine. The values are indicated in Table 1.

Table 1

Driving machine	Shock factor $K_S$
Electric motor	0,8
Internal combustion engine	0,7
Diesel engine	0,6

Thus:

$$1,5 \cdot T_N \leq T_{perm} \cdot K_S$$

$T_N$  = Normal operating torque (Nm)

$T_{perm}$  = Maximum permissible torque of the coupling (Nm)

$K_S$  = Shock factor in accordance with Table 1

The following applies as a guide value for determining the release torque:

$$T_A \geq 1,2 \cdot T_{max}$$

$T_A$  = Release torque (Nm)

$T_{max}$  = Max. occurring operating torque (Nm)

The release torque determined in this way must lie within the chosen coupling's torque range. When checking this value, the following condition must be fulfilled:

$$T_A \leq T_{perm} \cdot K_S$$

## Temperature

Thanks to the design, the temperature has only a relatively slight influence on the coupling's torque behavior. The standard design can be used at temperatures within a range from  $-30^\circ\text{C}$  to  $+70^\circ\text{C}$ .

The oil viscosity may, however, change at operating temperatures below  $0^\circ\text{C}$ .

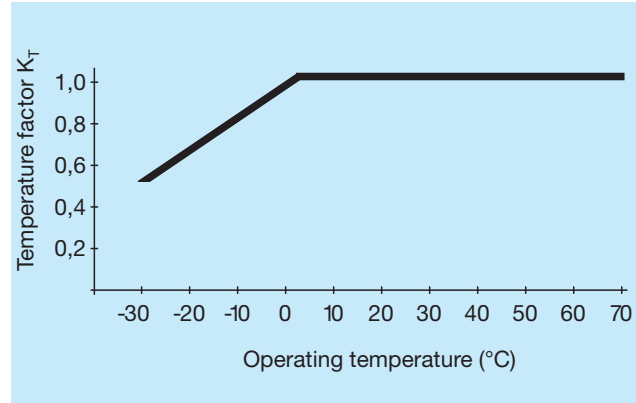

Diagram 1

This leads to an extension of the switching time and thus to an increase in the friction work on release. For this reason, it is necessary to reduce the maximum permissible release torque for such temperatures. The following formula is used for calculation:

$$T_R = T_{perm} \cdot K_T$$

$T_R$  = Torque of the coupling reduced to operating temperature (Nm)

$T_{perm}$  = Max. permissible torque of the coupling (Nm)

$K_T$  = Temperature factor referred to operating temperature

As when making a choice without the temperature factor, the calculation must also include the shock factor  $K_S$  for rotary drives as indicated in Table 1. Then check whether the required release torque lies below the reduced maximum permissible

torque.

The following conditions apply:

$$T_A \leq T_R \cdot K_S$$

or

$$T_A \leq T_{perm} \cdot K_T \cdot K_S$$

Please consult us for applications which are above or below the stated range, i.e.  $-30^\circ\text{C}$  to  $+70^\circ\text{C}$ . Provided particular design measures are taken into account, the HYGUARD® safety couplings can also be used in these conditions.

### • Note

The  $T_{perm}$  values can be found in the selection tables of the various coupling types. The upper value of the torque range applies in each case. The temperature factor  $K_T$  is to be determined from Diagram 1.

## Bearings

Depending on the application, HYGUARD® safety couplings are supplied with standard slide bearings, or with built-in roller bearings.

As far as the slide bearing options are concerned, the relevant restrictions and limitations have to be observed in order to avoid wear and unacceptable heating. As such, the sliding velocity after release shall not exceed the value of 1,5 m/s. A maximum value of 1 N/mm<sup>2</sup> is applicable for the surface loading of the bearing.

The verification of the surface pressure considering the influence of the radial forces can be effected by means of the following formula:

For safety couplings of the construction series B:

$$P = \frac{F}{1,2 \cdot d_1^2}$$

For safety couplings of the construction series BN:

$$P = \frac{F}{D \cdot d_2 \cdot 0,9}$$

P = surface pressure of the bearing (N/mm<sup>2</sup>)

F = radial force acting on the bearing (N)

d<sub>1</sub>, d<sub>2</sub> = bearing diameter (mm) acc. to selection table B, BN

D = length dimension (mm) acc. to selection table BN

In both cases, the calculation must result in a value which meets the following condition:

$$P \leq 1 \text{ N/mm}^2$$

If this value is exceeded, the next larger size, or a design with roller bearings has to be selected. The same holds good for applications requiring higher speeds than the max. speeds which are indicated in the selection tables.

## Sequence of release

The diagram below shows the progression of HYGUARD® safety coupling release. At the moment of release, the torque drops abruptly by 30% to 40%. The joint assumes a sliding function.

The connection is released completely within 10 msec. There are no dangerous torque peaks beyond the set cut-off torque. This is a further safety advantage offered by the safety coupling.

## Materials

As a rule, a material of ST 60 steel quality suffices for normal cylindrically ground shafts onto which the safety element is fitted directly.

• Note  
Keyed shafts call for compensation bushes to bridge over the keyway, in order to ensure optimum fit of the coupling. There is no need for this compensation bush if BN or BWN types will be used, as they are specially provided for being assemb-

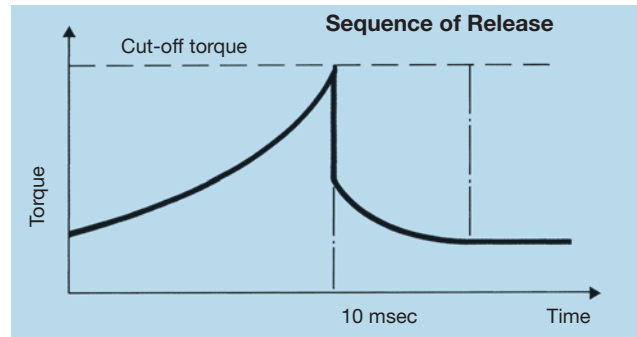

Diagram 2

led with keyed shafts. Various materials can be used as hub material, such as steel alloys, grey cast iron or aluminium.

However, the differences in strength must be taken into account. This applies particularly for dimensioning the hub wall thicknesses. Here, specific diameter ratios must be observed in order to attain the required surface pressure between the coup-

Table 2

Hub material	Diameter ratio d <sub>1</sub> , d <sub>2</sub>
Steel alloy	1,5
Nodular cast iron	1,8
Grey cast iron	2,0
Aluminium	2,4

ling and hub. Varying values apply here depending on the material. These values are listed in Table 2.

## Shear tubes

The release time of the coupling is always shorter the quicker the pressure is reduced. Several shear tubes can be applied in case of larger coupling sizes or for special designs, (table 3).

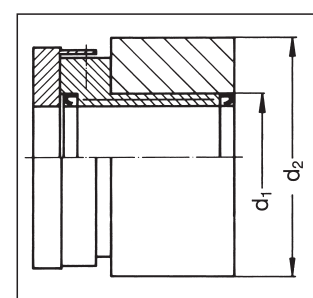

Type	Coupling diameter	Number shear tubes
B	all sizes	1
BN	all sizes	1
BW	< BW 140	1
BWN	< BWN 100	1
BWL	< BWL 140	1
BW	≥ BW 140	2
BWN	≥ BWN 100	2
BWL	≥ BWL 140	2

Table 3



## Surface roughness and tolerance

HYGUARD® Safety couplings transmit the torque exclusively by friction of the mating surfaces. The manufacturing accuracy of the machine parts to be joined therefore exerts an influence on the transmission reliability. This applies to the strict adherence of certain tolerances and to the roughness of the contact faces. The surface roughness specification is the same for all the HYGUARD® types. The tolerance fields, however, vary in accordance with the series used. Table 4 contains all the data required.

## Protection

A protection band is used to protect the shear tubes. On release, the band retains the cut-off heads of the shear tubes and the escaping oil. A protective band made of rubber is used for outer diameters up to 240 mm. A metal band is required for larger diameters. A protection band of metal is also recommended for drives with higher speeds because the rubber band may expand under the influence of centrifugal force. The width of the protection band must fully cover the width of the safety valve.

## Lubrication

After release, the safety element operates as a slide bearing. An oil supply is provided in the coupling for lubricating the sliding faces. This is filled up through a special screw plug during installation. The lubricating oil chamber is not linked to the pressure chamber. Additionally fitted seals reliably prevent the loss of lubricant, thus guaranteeing lubrication even after longer periods of operation. Special surface treatment of the coupling sleeve additionally improves the sliding properties. If the assembly is treated properly, no wear of the contact faces is to be expected even after a great number of releases.

## HDW series

The HDW special series of HYGUARD® safety couplings was developed particularly for the transmission of high torques. It transmits the torque from the shaft direct onto the flange hub without straining the safety element itself. Here, the element merely performs a clamping function. This also ensures that the connecting points of the inner and outer safety sleeves, which are extremely pressure-tight, are not subjected to the torque. This explains the high capacity of this design. Owing to its compact design, the HDW-series is particularly suitable for use in rolling mill stands. The connection is

accomplished by a flange, so that the attachment of curved tooth spindles or cardan shafts is possible without difficulties. The safety couplings of the HDW series can also replace conventional flanges, a fact being of particular interest for retrofittings. The roller bearing which is mounted on the flange side, is rated for taking up higher radial loads.

## HWF series

Despite their compact dimensions, safety couplings in the HWF series transmit high torques. They therefore fulfil the demands placed on applications in roll stands, for instance. Their dimensions are adapted for combination with curved tooth articulated spindles. Combination with other cardan shafts is, however, just as possible. HYGUARD® couplings in the HWF series are therefore particularly recommended for use in the steel industry.

Component	Series	Tolerance Field Shaft/Bore	Surface Roughness
Shaft	B BW	h 6	$R_A = 0,8 \mu\text{m}$
	BN BWN	h 6	$R_A = 1,6 \mu\text{m}$
Hub	B BW	K7	$R_A = 1,6 \mu\text{m}$
	BN BWN	H 6	$R_A = 0,8 \mu\text{m}$ $R_A = 1,6 \mu\text{m}$

Table 4

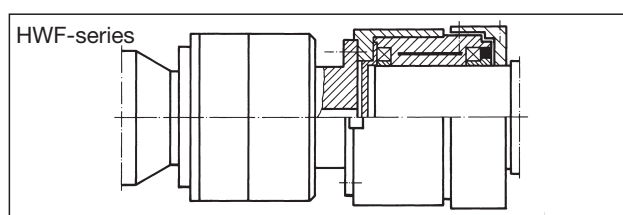
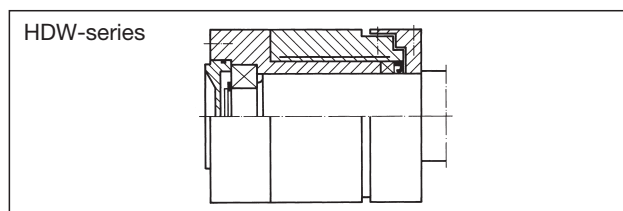
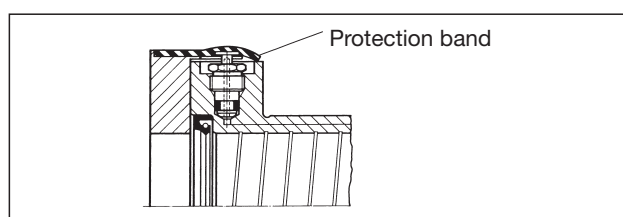

# HYGUARD® Safety Couplings

## Series B



Table of Dimensions No. 243 080

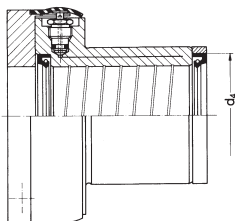
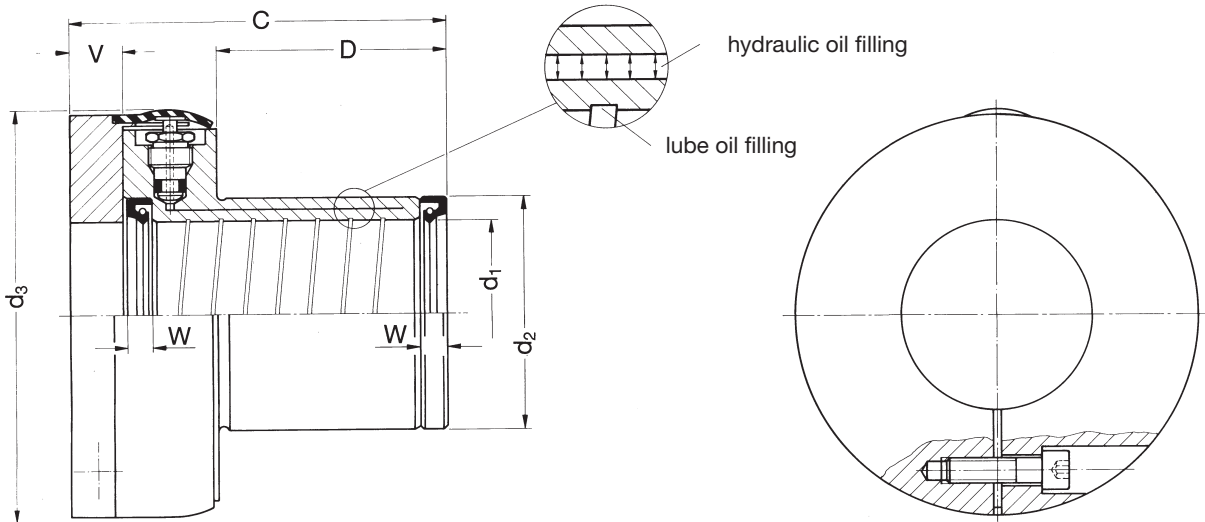

• Note

Dimension  $d_4$  is only valid for sizes 170 to 220, as there is a difference between the outside diameter  $d_2$  of the clamping element and the outside diameter of the radial seal.

Dimensions are subject to change due to technical progress.

This B series is the basic element of the HYGUARD® safety coupling. Thanks to its compact dimensions, it can be combined with a very wide range of drive elements without influencing their torque capacity. At the same time, the safety coupling sleeve is equally suitable for clamping fixed and rotating parts.

After release, the coupling acts like a sliding bearing. However, the circumferential speed on the sliding face should not exceed 1.5 m/s. This is why the B series is preferably suitable for low-speed drives.

1) Higher speeds on request  
**For surface roughness and tolerances, please see page 9.**

Type B	Torque Range T ~ Nm	Speed <sup>1)</sup> $n_{max}$ rpm	Dimensions								Weight kg	Mass Moment of Inertia J kgm <sup>2</sup>
			$d_1$ mm	$d_2$ mm	$d_3$ mm	$d_4$ mm	C mm	D mm	V mm	W mm		
30	300 – 600	955	30	40	98	–	82	40	12	4	1,9	0,0020
35	450 – 900	818	35	45	104	–	87	45	12	4	2,1	0,0025
40	650 – 1300	716	40	52	109	–	94	52	12	5	2,5	0,003
45	850 – 1700	636	45	58	116	–	102	60	12	7	2,8	0,004
50	1100 – 2200	572	50	65	122	–	109	65	14	8	3,4	0,006
60	1800 – 3600	477	60	75	133	–	117	73	14	8	4,0	0,009
70	3000 – 6000	409	70	90	148	–	130	82	18	8	5,7	0,015
80	3900 – 7800	358	80	100	157	–	146	98	18	8	6,6	0,020
90	5000 – 10000	318	90	110	168	–	158	110	18	8	7,6	0,028
100	7500 – 15000	286	100	125	183	–	180	120	22	12	12	0,052
110	10000 – 20000	260	110	140	201	–	176	121	20	12	13	0,073
120	13000 – 25000	238	120	150	209	–	205	145	22	12	16	0,095
130	17000 – 33000	220	130	160	218	–	214	156	20	12	17	0,11
140	20000 – 40000	204	140	170	228	–	225	165	22	13	20	0,15
150	23000 – 46000	190	150	180	238	–	235	175	22	13	22	0,18
160	36000 – 71000	179	160	200	246	–	260	195	20	15	27	0,26
• 170	39000 – 78000	168	170	210	256	200	256	191	20	15	28	0,29
• 180	49000 – 98000	159	180	225	274	210	256	191	20	15	32	0,37
• 190	63000 – 126000	150	190	240	286	220	302	236	17	15	43	0,54
• 200	70000 – 140000	143	200	250	296	230	302	236	17	15	45	0,61
• 220	85000 – 170000	130	220	270	314	250	302	236	17	15	49	0,76

# HYGUARD® Safety Couplings

## Series BW



Table of Dimensions 243 081

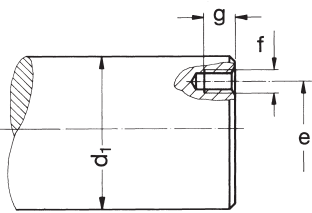
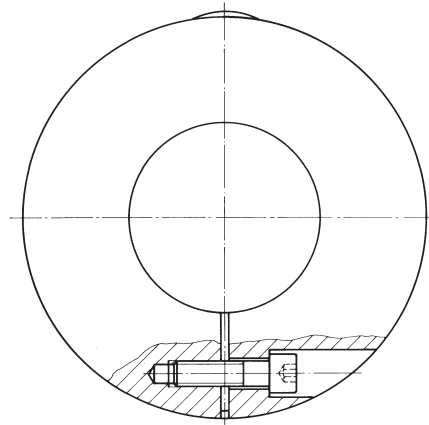
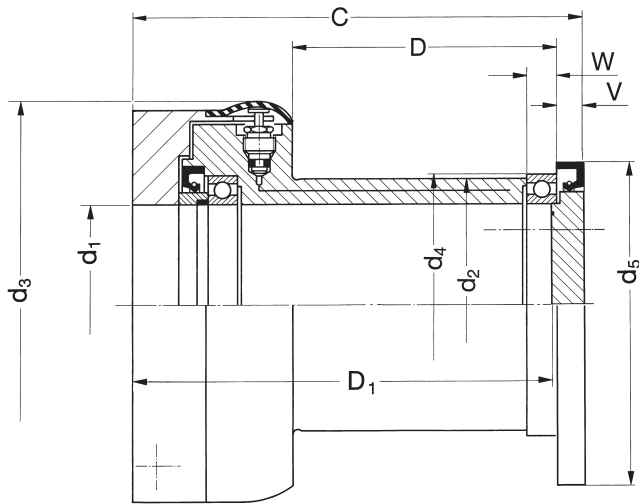

The HYGUARD® series BW essentially corresponds to the basic element B, but is additionally equipped with roller bearings. The BW is therefore also suitable for higher-speed drives.

Contrary to the version with sleeve bearing only, this type is mainly used in applications in which circumferential speeds of more than 1,5 m/s

have to be expected in the bearing after release. Yet, the space required by the safety element itself is hardly bigger than for the B-design.

1) Higher speeds on request

**For surface roughness and tolerances, please see page 9.**

Shaft connecting dimensions to attach bearing cover			
Type BW	Pitch Circle e Ø mm	Size of Thread f Number	Depth of Tread g mm
60	40	4xM 6	13
70	50	4xM 6	13
80	50	4xM 6	13
90	65	4xM 8	18
100	70	4xM 8	18
110	80	4xM 8	18
120	90	4xM 8	18
130	100	4xM 8	18
140	105	4xM10	23
150	115	4xM10	23
160	120	4xM10	23
170	130	4xM10	23
180	135	4xM10	23
190	145	4xM10	23
200	150	4xM10	23
220	175	4xM10	23

Dimensions are subject to change due to technical progress.

Type BW Size	Torque Range T ~ Nm	Speed <sup>1)</sup> n <sub>max.</sub> rpm	Dimensions								Weight kg	Mass Moment of Inertia J kgm <sup>2</sup>			
			d <sub>1</sub> mm	d <sub>2</sub> mm	d <sub>3</sub> mm	d <sub>4</sub> mm	d <sub>5</sub> mm	C mm	D mm	D <sub>1</sub> mm			V mm	W mm	
60	1800 – 3600	7500	60	75	136	78	90	136,5	75	128	+/-0,2	7	10	4,9	0,012
70	3000 – 6000	6700	70	90	148	90	100	150	84	140,5	+/-0,2	7	10	6,6	0,020
80	3900 – 7800	6000	80	100	157	100	110	166	100	156,5	+/-0,2	8	10	7,6	0,025
90	5000 – 10000	5300	90	110	168	115	125	184	111	170	+/-0,2	12	13	9,2	0,037
100	7500 – 15000	4800	100	125	183	125	140	206	121	191	+/-0,2	12	13	14	0,065
110	10000 – 20000	4300	110	140	201	140	150	208	125	193	+/-0,2	12	16	16	0,095
120	13000 – 25000	3800	120	150	209	150	160	237	148	221	+/-0,2	13	16	19	0,12
130	17000 – 33000	3600	130	160	218	165	170	250	161	234	+/-0,2	13	18	21	0,14
140	20000 – 40000	3400	140	170	228	175	180	261	170	245	+/-0,2	13	18	24	0,19
150	23000 – 46000	3000	150	180	238	190	190	275	182	259	+/-0,2	13	20	27	0,23
160	36000 – 71000	2800	160	200	253	200	200	300	202	284	+/-0,2	13	20	32	0,32
170	39000 – 78000	2600	170	210	258	215	215	300	198	282	+/-0,2	15	22	34	0,37
180	49000 – 98000	2400	180	225	273	225	225	300	197	281	+/-0,2	16	22	38	0,46
190	63000 – 126000	2200	190	240	286	240	250	350	245	332	+/-0,2	15	24	50	0,66
200	70000 – 140000	2200	200	250	296	250	250	350	245	332	+/-0,2	15	24	53	0,75
220	85000 – 170000	1900	220	270	320	270	270	350	245	332	+/-0,2	15	24	57	0,93

# HYGUARD® Safety Couplings

## Series BN



Table of Dimensions No. 243 082

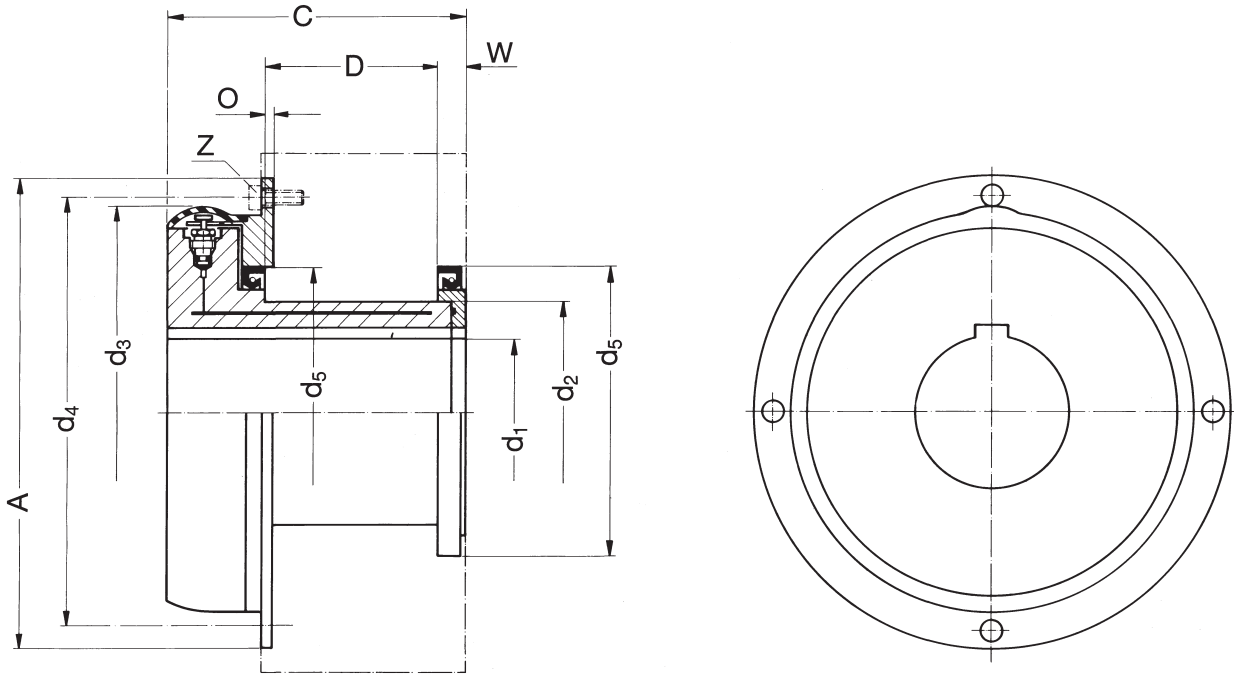

The HYGUARD® series BN is designed for drives with keyed shaft. This model has an integrated keyway, and is therefore particularly suitable for converting existing drives. Intermediate sleeves to com-

pensate changes in diameters are not required. On this version, the sliding surface is located on the outer diameter. The sliding velocity should not exceed 1.5 m/s.

1) Higher speeds on request

**For surface roughness and tolerances, please see page 9.**

Dimensions are subject to change due to technical progress.

Type BN	Torque Range T ~ Nm	Speed <sup>1)</sup> n <sub>max.</sub> rpm	Dimensions											Weight kg	Mass Moment of Inertia J kgm <sup>2</sup>
			d <sub>1</sub> mm	d <sub>2</sub> mm	d <sub>3</sub> mm	d <sub>4</sub> mm	d <sub>5</sub> mm	A mm	C mm	D mm	Z	W mm	O mm		
52	600 – 1200	551	26 – 35	52	114	121	72	135	80	31	M 6x4	9	4	5,4	0,008
60	1000 – 2000	477	30 – 40	60	119	131	90	145	95	46	M 6x4	9	4	6,7	0,010
70	1500 – 2900	409	38 – 48	70	128	140	100	154	100	51	M 6x4	9	4	7,9	0,013
80	2100 – 4200	358	45 – 55	80	139	147	110	161	105	56	M 6x4	9	4	8,9	0,017
90	3000 – 6000	318	50 – 60	90	147	157	125	171	115	58	M 6x4	13	4	11	0,024
100	3900 – 7800	286	60 – 70	100	157	166	140	180	125	68	M 6x4	13	4	14	0,034
110	5000 – 10000	260	65 – 80	110	167	177	150	191	130	73	M 6x4	13	4	16	0,046
120	7000 – 14000	239	70 – 85	120	174	183	160	197	140	83	M 6x4	13	4	18	0,059
130	9000 – 17000	220	80 – 95	130	184	196	170	211	150	93	M 8x4	13	4	20	0,080
140	10000 – 20000	205	80 – 105	140	194	204	180	219	160	103	M 8x4	13	4	23	0,10
150	13000 – 25000	191	95 – 115	150	202	213	185	228	170	117	M 8x4	11	4	25	0,13
160	17000 – 33000	179	100 – 120	160	212	223	190	238	180	117	M 8x4	16	4	29	0,16
180	23000 – 46000	159	115 – 135	180	235	246	220	262	190	133	M 8x4	13	4	35	0,22
200	35000 – 70000	143	130 – 155	200	256	266	240	282	200	137	M 8x4	16	4	44	0,36
220	48000 – 96000	130	140 – 170	220	276	286	260	302	230	167	M 8x4	16	4	58	0,55
250	70000 – 140000	115	160 – 190	250	294	316	290	332	250	185	M 8x4	17	4	74	0,88
280	90000 – 180000	102	180 – 210	280	322	345	320	360	270	205	M 8x4	17	4	101	1,53

# HYGUARD® Safety Couplings Series BWN



Table of Dimensions No. 243 083

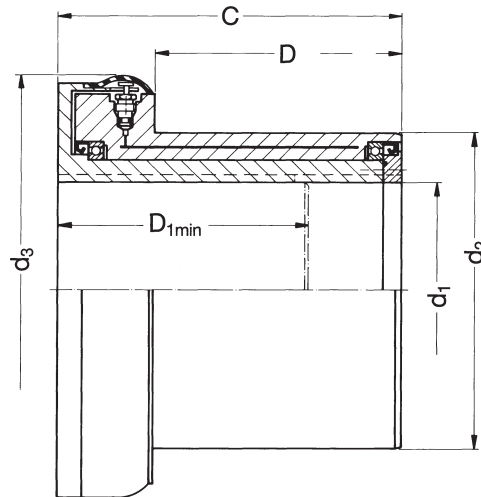

The HYGUARD® BWN series is an extension of the BN series and is also equipped with an integrated keyway. It is therefore just as suitable for conversions as for new systems. Two roller bearings

are additionally incorporated, thus depending with the limitation of the sliding velocity to 1.5 m/s. BWN models are therefore also suitable for higher-speed drives.

1) Higher speeds on request

**For surface roughness and tolerances, please see page 9.**

Dimensions are subject to change due to technical progress.

Type <b>BWN</b>	Torque Range T ~ Nm	Speed <sup>1)</sup> n <sub>max.</sub> rpm	Dimensions						Weight kg	Mass Moment of Inertia J kgm <sup>2</sup>
			d <sub>1</sub> mm	d <sub>2</sub> mm	d <sub>3</sub> mm	C mm	D mm	D <sub>1 min</sub> mm		
<b>50</b>	1700 – 3400	5300	40 – 50	80	138	105	67	80	5,7	0,011
<b>60</b>	2500 – 5000	5300	50 – 60	95	153	110	71	82	7,5	0,018
<b>70</b>	3750 – 7500	4500	60 – 70	110	166	125	83	105	10	0,031
<b>80</b>	6500 – 13000	3400	70 – 80	125	183	140	98	120	14	0,050
<b>90</b>	9000 – 18000	2800	80 – 90	145	201	160	113	130	20	0,093
<b>100</b>	11500 – 23000	2600	90 – 100	160	218	175	122	140	26	0,139
<b>110</b>	17000 – 34000	2600	100 – 110	175	228	190	137	145	31	0,197
<b>120</b>	20500 – 41000	2400	110 – 120	190	243	200	146	155	37	0,263
<b>130</b>	28000 – 56000	2000	120 – 130	205	256	220	164	160	44	0,345
<b>145</b>	35500 – 71000	1700	130 – 145	220	268	230	173	170	51	0,460
<b>155</b>	41000 – 82000	1600	140 – 155	240	286	260	193	180	69	0,721
<b>165</b>	55000 – 110000	1500	150 – 165	255	301	285	218	190	83	0,976
<b>185</b>	75000 – 150000	1500	160 – 185	280	333	300	233	210	113	1,65



# HYGUARD® Safety Couplings

## Series BWL



Table of Dimensions No. 243 084

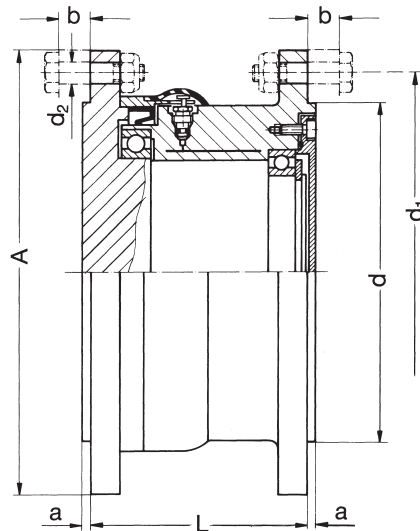

HYGUARD® Safety couplings of the BWL series consist of a shaft part and a bush and thus already constitute a complete coupling unit. They are equipped on both sides with connection flanges and as such, can also be used, for instance, as intermediate elements for curved tooth couplings or other connec-

tion elements. This links the advantages of the curved tooth couplings with those of the safety unit to obtain a flexible safety coupling with torque limitation. One advantage is that the coupling itself does not have to be altered. The BWL model is therefore suitable for the later conversion of existing couplings.

1) Higher speeds of request

Dimensions are subject to change due to technical progress.

Type BWL	Torque Range T ~ Nm	Speed <sup>1)</sup> n <sub>max.</sub> rpm	Dimensions								Number of Holes	Weight kg	Mass Moment of Inertia J kgm <sup>2</sup>
			d mm	d <sub>1</sub> mm	d <sub>2</sub> mm	A mm	a mm	b mm	L mm				
30	400 – 800	6700	80	102	8	118	2	12	80	6	5,9	0,0095	
40	710 – 1420	6000	95	126	9	145	2	12,5	90	6	10,6	0,027	
50	1400 – 2800	5300	110	145	9	165	2	12,5	110	8	15,6	0,048	
60	2500 – 5000	4300	135	175	11	200	2,5	15	105	8	22,6	0,096	
70	4000 – 8000	3800	150	192	11	220	3	15	110	10	27,6	0,145	
80	5600 – 11200	3600	170	210	11	240	3	15	120	12	36,5	0,223	
90	8000 – 16000	3000	190	242	14	270	4	17,5	130	10	51,1	0,403	
100	11200 – 22400	2800	200	248	14	280	4	17,5	140	12	59,1	0,5	
110	14000 – 28000	2600	220	274	17	310	4	23	150	12	75,6	0,79	
125	22400 – 44800	2200	250	302	17	340	5	23	160	16	97,5	1,16	
140	31500 – 63000	1900	280	342	20	390	5	26	170	14	134,1	2,12	
160	45000 – 90000	1800	320	386	24	435	5	29	180	14	178,8	3,64	
180	63000 – 126000	1700	360	430	24	480	5	29	195	16	234,5	5,69	
200	90000 – 180000	1500	410	486	28	545	6	34	210	16	323,3	10,14	
220	125000 – 250000	1500	450	525	28	580	8	36	230	18	378	12,71	

# Curved Tooth Couplings SB with HYGUARD® Safety Couplings BW

Table of Dimensions No. 243 085

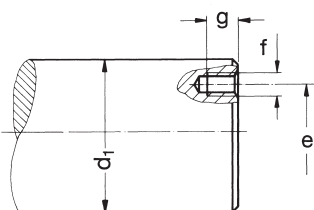
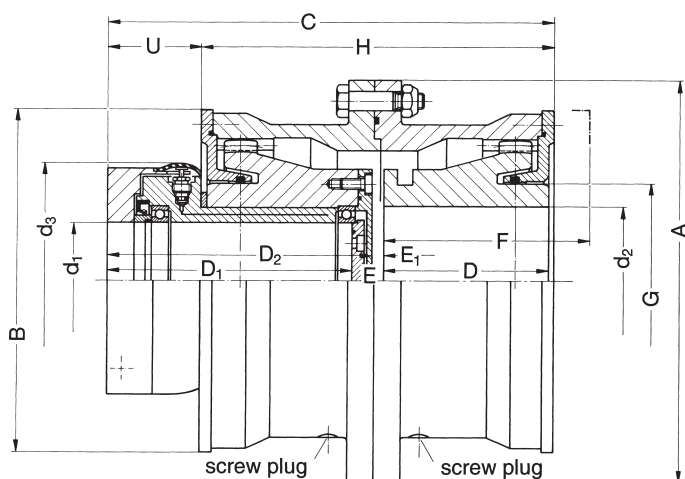

Here, the BW-safety coupling is combined with the SB-type curved tooth coupling. This produces a double engagement safety coupling for universal use. The maximum permissible angular offset of each coupling half is  $\pm 1,5$  degrees, or, for special ver-

sions, up to  $\pm 3$  degrees. The SB-type curved tooth coupling is designed for oil lubrication, but grease lubrication is possible, too.

1) Values of complete coupling with max.  $d_2$

Shaft connecting dimensions to attach bearing cover			
Type BW	Pitch Circle e	Size of Thread f	Depth of Thread g
Size	Ø mm	Number	mm
60	40	4xM8	15
70	50	4xM8	15
80	55	4xM8	15
90	60	4xM8	15
100	70	4xM8	20
110	75	4xM8	20
120	85	4xM8	20
130	100	4xM8	20
140	100	4xM8	20
150	120	4xM8	20
160	120	4xM10	20
170	125	4xM10	20
180	130	4xM10	20
190	140	4xM10	20
200	150	4xM12	25
220	170	6xM12	25

Dimensions are subject to change due to technical progress.

Type Combination SB/BW Size	Torque Range T ~ Nm	Bore		Dimensions														Weight <sup>1)</sup> kg	Mass Moment of Inertia <sup>1)</sup> J kgm <sup>2</sup>
		d <sub>1</sub> mm	d <sub>2</sub> rough min max mm mm mm	d <sub>3</sub> mm	A mm	B mm	C mm	D mm	D <sub>1</sub> mm	D <sub>2</sub> mm	E mm	E <sub>1</sub> mm	F mm	G mm	H mm	U mm			
70/ 60	1800 – 3600	60	26 28 78	133	220	178	249	90	125 <sup>+0,5</sup>	150	31	6	130	100	192	57	31	0,145	
80/ 70	3000 – 6000	70	30 32 92	148	240	196	273	100	138 <sup>+0,5</sup>	164	32	6	150	120	212	61	39	0,219	
90/ 80	3900 – 7800	80	30 32 100	157	270	225	296	110	154 <sup>+0,5</sup>	174	28	8	170	130	236	60	55	0,405	
100/ 90	5000 – 10000	90	53 55 110	168	280	240	320	120	167 <sup>+0,5</sup>	188	29	8	180	140	256	64	65	0,531	
110/100	7500 – 15000	100	63 65 120	184	310	265	352	130	189 <sup>+0,5</sup>	210	29	8	190	155	276	76	86	0,885	
125/110	10000 – 20000	110	73 75 138	201	340	295	394	150	190 <sup>+0,5</sup>	229	49	10	215	175	320	74	116	1,45	
140/120	13000 – 25000	120	83 85 156	209	390	325	429	165	218 <sup>+0,5</sup>	249	41	10	230	200	350	79	161	2,53	
160/140	20000 – 40000	140	118 120 180	229	435	370	476	190	242 <sup>+0,5</sup>	268	38	12	270	230	404	72	227	4,52	
180/160	36000 – 71000	160	138 140 200	247	480	415	539	220	280 <sup>+0,5</sup>	305	37	12	300	260	456	83	317	7,82	
200/170	39000 – 78000	170	158 160 225	257	545	465	595	245	280 <sup>+0,5</sup>	332	69	14	340	290	512	83	462	14,56	
220/200	70000 – 140000	200	158 160 250	292	580	510	662	270	327 <sup>+0,5</sup>	360	49	16	360	355	556	106	567	20,45	
240/220	85000 – 170000	220	178 180 275	312	645	560	706	290	327 <sup>+0,5</sup>	380	71	18	380	390	598	108	714	30,85	

# Curved Tooth Couplings SBk with HYGUARD® Safety Couplings BW

Table of Dimensions No. 243 086

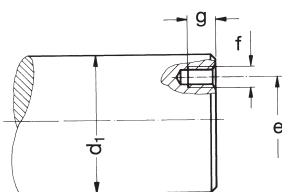
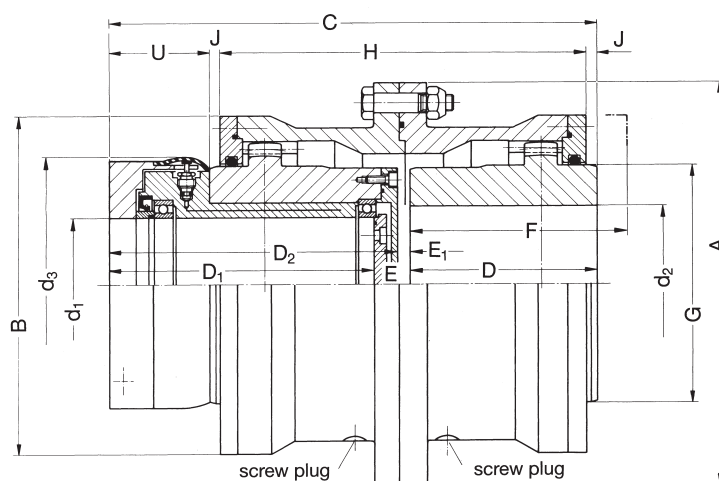

In this version, the HYGUARD® BW safety element is combined with the curved tooth coupling of the SBk construction series. Contrary to the SB-design, this double engagement coupling only allows less angular offset, i.e.  $\pm 0,75$  degrees, and  $\pm 2$  degrees for special designs. The sleeve is

centered over a combined tooth tip/tooth flank centering. Curved tooth couplings of the SBk-series are intended for grease lubrication. Serving as safety coupling, this combination is also suitable for heavy-duty drives.

1) Values for complete coupling with max.  $d_2$

Shaft connecting dimensions to attach bearing cover			
Type BW	Pitch Circle e	Size of Thread f	Depth of Thread g
Size	Ø mm	Number	mm
60	40	3xM8	15
70	50	4xM8	15
80	55	4xM8	15
90	60	4xM8	15
100	70	4xM8	20
110	75	4xM8	20
120	85	4xM8	20
130	100	4xM8	20
140	100	4xM8	20
150	120	4xM8	20
160	120	4xM10	20
170	125	4xM10	20
180	130	4xM10	20
190	140	4xM10	20
200	150	4xM12	25
220	170	6xM12	25

Dimensions are subject to change due to technical progress.

Type Combination SBk/BW Size	Torque Range T ~ Nm	Bore				Dimensions														Weight <sup>1)</sup> kg	Mass Moment of Inertia <sup>1)</sup> J kgm <sup>2</sup>
		d <sub>1</sub> mm	d <sub>2</sub> mm			d <sub>3</sub> mm	A mm	B mm	C mm	D mm	D <sub>1</sub> mm	D <sub>2</sub> mm	E mm	E <sub>1</sub> mm	F mm	G mm	H mm	J mm	U mm		
70/ 60	1800 – 3600	60	26	28	80	133	200	160	240	90	125 <sup>+0,5</sup>	144	25	6	120	112,5	178	4	54	30	0,099
80/ 70	3000 – 6000	70	26	28	92	148	220	178	264	100	138 <sup>+0,5</sup>	158	26	6	130	128	198	4	58	34	0,165
90/ 80	3900 – 7800	80	30	32	105	157	240	196	286	110	154 <sup>+0,5</sup>	168	22	8	140	145	218	5	58	41	0,245
100/ 90	5000 – 10000	90	30	32	115	168	270	225	319	125	167 <sup>+0,5</sup>	186	27	8	150	160,5	244	7	61	62	0,463
110/100	7500 – 15000	100	53	55	126	184	280	240	361	140	189 <sup>+0,5</sup>	213	32	8	170	176	264	12	73	73	0,615
125/110	10000 – 20000	110	63	65	145	201	310	265	381	150	190 <sup>+0,5</sup>	221	41	10	180	200,5	284	13	71	94	1,01
140/130	17000 – 33000	130	73	75	162	219	340	295	426	170	231 <sup>+0,5</sup>	246	25	10	200	224,5	330	10	76	132	1,72
160/150	23000 – 46000	150	83	85	185	239	390	325	472	190	255 <sup>+0,5</sup>	270	27	12	230	256,5	360	16	80	181	3,01
180/160	36000 – 71000	160	118	120	210	247	435	370	537	220	280 <sup>+0,5</sup>	305	37	12	260	288,5	416	18	85	255	5,34
200/180	49000 – 98000	180	138	140	230	269	480	415	601	250	276 <sup>+0,5</sup>	337	75	14	300	320,5	476	19	87	343	8,86
225/200	70000 – 140000	200	158	160	260	292	545	465	666	280	327 <sup>+0,5</sup>	370	59	16	330	362	532	22	90	506	16,48
250/220	85000 – 170000	220	158	160	280	312	580	510	710	300	327 <sup>+0,5</sup>	370	83	40	350	400	556	32	90	616	22,89

# Curved Tooth Couplings SBk with HYGUARD® Safety Couplings BW



Table of Dimensions No. 243 195

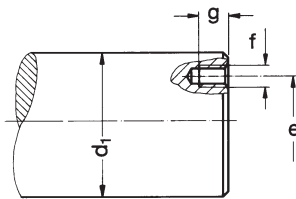
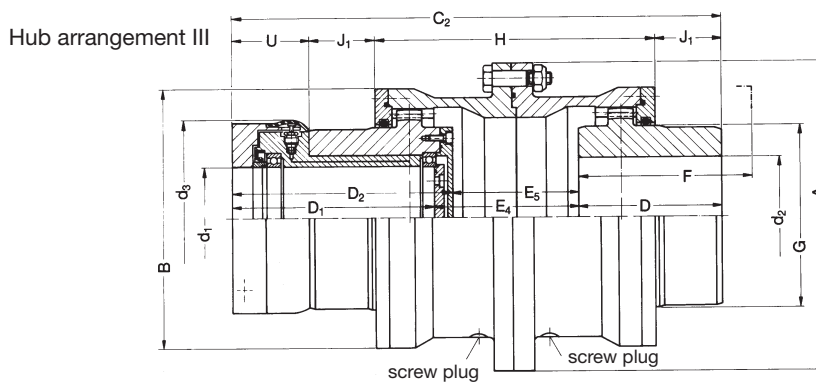
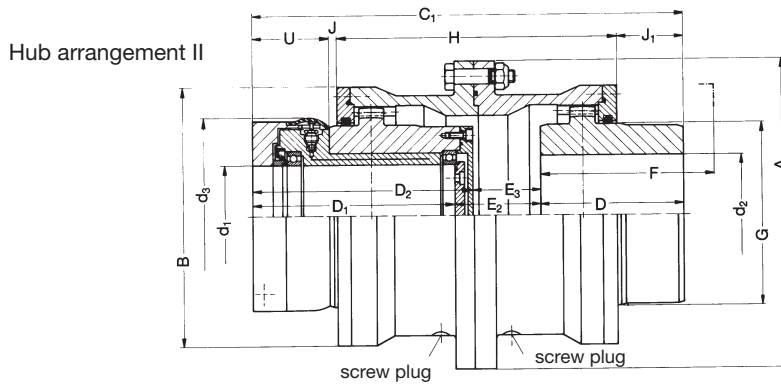

The structure of the SBk-series allows different arrangements of the hub in the housing, so that greater shaft distances can be bridged over. In case of taper bores the enlarged E-dimension provides space for the use of shaft nuts.

1) Values for complete coupling with max  $d_2$

Shaft connecting dimensions to attach bearing cover			
Type BW	Pitch Circle e Ø mm	Size of Thread f Number	Depth of Thread g mm
60	40	3xM8	15
70	50	4xM8	15
80	55	4xM8	15
90	60	4xM8	15
100	70	4xM8	20
110	75	4xM8	20
120	85	4xM8	20
130	100	4xM8	20
140	100	4xM10	20
150	120	4xM8	20
160	120	4xM10	20
170	125	4xM10	20
180	130	4xM10	20
190	140	4xM10	20
200	150	4xM12	25
220	170	6xM12	25

Type Com- bination SBk/BW Size	Dimensions with Hub Arrangement III		
	C <sub>2</sub> mm	E <sub>4</sub> mm	E <sub>5</sub> mm
70/ 60	312	97	78
80/ 70	348	110	90
90/ 80	382	118	104
100/ 90	421	129	110
110/100	469	140	116
125/110	497	157	126
140/130	566	165	150
160/150	616	171	156
180/160	713	213	188
200/180	805	279	218
225/200	890	283	240
250/220	974	347	304

Dimensions are subject to change due to technical progress.

Type Com- bination SBk/BW Size	Torque Range T ~ Nm	d <sub>1</sub> mm	Bore d <sub>2</sub>				Dimensions with Hub Arrangement II														Weight <sup>1)</sup> kg	Mass Moment of Inertia <sup>1)</sup> J kgm <sup>2</sup>
			rough mm	min mm	max mm		d <sub>3</sub> mm	A mm	B mm	C <sub>1</sub> mm	D mm	D <sub>1</sub> mm	D <sub>2</sub> mm	E <sub>2</sub> mm	E <sub>3</sub> mm	F mm	G mm	H mm	J mm	J <sub>1</sub> mm		
70/ 60	1800 – 3600	60	26	28	80	133	200	160	276	90	125 <sup>+0.5</sup>	144	61	42	120	112,5	178	4	40	54	30	0,099
80/ 70	3000 – 6000	70	26	28	92	148	220	178	306	100	138 <sup>+0.5</sup>	158	68	48	130	128	198	4	46	58	34	0,165
90/ 80	3900 – 7800	80	30	32	105	157	240	196	334	110	154 <sup>+0.5</sup>	168	70	56	140	145	218	5	53	58	41	0,245
100/ 90	5000 – 10000	90	30	32	115	168	270	225	370	125	167 <sup>+0.5</sup>	186	78	59	150	160,5	244	7	58	61	62	0,463
110/100	7500 – 15000	100	53	55	126	184	280	240	415	140	189 <sup>+0.5</sup>	213	86	62	170	176	264	12	66	73	73	0,615
125/110	10000 – 20000	110	63	65	145	201	310	265	439	150	190 <sup>+0.5</sup>	221	99	68	180	200,5	284	13	71	71	94	1,01
140/130	17000 – 33000	130	73	75	162	219	340	295	496	170	231 <sup>+0.5</sup>	246	95	80	200	224,5	330	10	80	76	132	1,72
160/150	23000 – 46000	150	83	85	185	239	390	325	544	190	255 <sup>+0.5</sup>	270	99	84	230	256,5	360	16	88	80	181	3,01
180/160	36000 – 71000	160	118	120	210	247	435	370	625	220	280 <sup>+0.5</sup>	305	125	100	260	288,5	416	18	106	85	255	5,34
200/180	49000 – 98000	180	138	140	230	269	480	415	703	250	276 <sup>+0.5</sup>	337	177	116	300	320,5	476	19	121	87	343	8,86
225/200	70000 – 140000	200	158	160	260	292	545	465	778	280	327 <sup>+0.5</sup>	370	171	128	330	362	532	22	134	90	506	16,48
250/220	85000 – 170000	220	158	160	280	312	580	510	842	300	327 <sup>+0.5</sup>	370	215	172	350	400	556	32	164	90	616	22,89

# Curved Tooth Couplings LBk with HYGUARD® Safety Coupling BW



Table of Dimensions No. 243 087

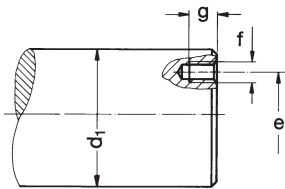
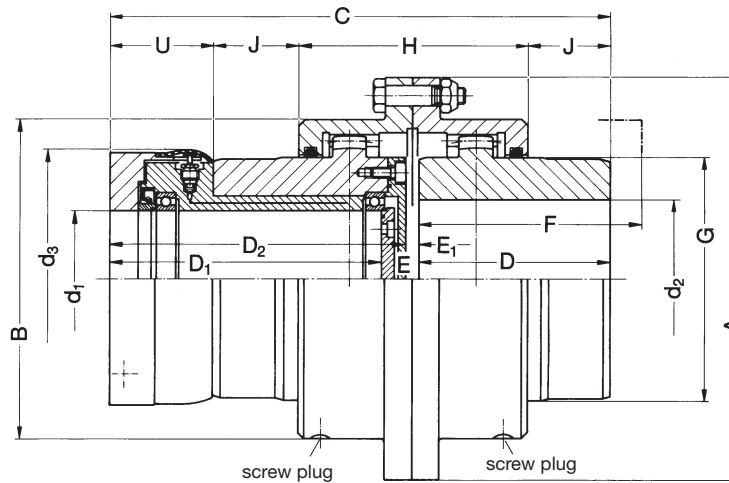

The HYGUARD® safety element BW in combination with the curved tooth coupling LBk is recommended for applications in which a shaft coupling with a simplified design suffices, but where full protection against overload is required. The angular offset of the curved

to the LBk series is  $\pm 0,75$  degrees per coupling half. The housing is tooth tip-tooth flank centered. The double engagement coupling is lubricated by grease and sealed by O-rings.

1) Values for complete coupling with max.  $d_2$

Shaft connecting dimensions to attach bearing cover			
Type BW	Pitch Circle e mm	Size of Thread f Number	Depth of Thread g mm
60	40	3xM8	15
70	50	4xM8	15
80	55	4xM8	15
90	60	4xM8	15
100	70	4xM8	20
110	75	4xM8	20
120	85	4xM8	20
130	100	4xM8	20
140	100	4xM8	20
150	120	4xM8	20
160	120	4xM10	20
170	125	4xM10	20
180	130	4xM10	20
190	140	4xM10	20
200	150	4xM12	25
220	170	6xM12	25

Dimensions are subject to change due to technical progress.

Type Combination LBk/BW Size	Torque Range T ~ Nm	$d_1$ mm	Bore $d_2$				Dimensions													Weight <sup>1)</sup> kg	Mass Moment of Inertia <sup>1)</sup> J kgm <sup>2</sup>
			rough mm	min mm	max mm		$d_3$ mm	A mm	B mm	C mm	D mm	$D_1$ mm	$D_2$ mm	E mm	$E_1$ mm	F mm	G mm	H mm	J mm		
70/ 60	1800 – 3600	60	26	28	80	133	195	145	240	90	125 <sup>+0,5</sup>	144	25	6	120	112,5	112	37	54	20	0,071
80/ 70	3000 – 6000	70	26	28	92	148	215	168	264	100	138 <sup>+0,5</sup>	158	26	6	130	128	119	43,5	58	27	0,116
90/ 80	3900 – 7800	80	30	32	105	157	230	185	286	110	154 <sup>+0,5</sup>	168	22	8	140	145	127	50,5	58	33	0,165
100/ 90	5000 – 10000	90	30	32	115	168	265	210	319	125	167 <sup>+0,5</sup>	186	27	8	150	160,5	148	55	61	50	0,323
110/100	7500 – 15000	100	53	55	126	184	270	224	361	140	189 <sup>+0,5</sup>	213	32	8	170	176	161	63,5	73	60	0,425
125/110	10000 – 20000	110	63	65	145	201	305	245	381	150	190 <sup>+0,5</sup>	221	41	10	180	200,5	175	67,5	71	78	0,735
140/130	17000 – 33000	130	73	75	162	219	330	270	426	170	231 <sup>+0,5</sup>	246	25	10	200	224,5	197	76,5	76	103	1,17
160/150	23000 – 46000	150	83	85	185	239	375	305	472	190	255 <sup>+0,5</sup>	270	27	12	230	256,5	221	85,5	80	147	1,87
180/160	35500 – 71000	160	118	120	210	247	425	348	537	220	280 <sup>+0,5</sup>	305	37	12	260	288,5	250	101	85	215	3,97
200/180	49000 – 98000	180	138	140	230	269	470	392	601	250	276 <sup>+0,5</sup>	337	75	14	300	320,5	272	121	87	283	6,66
225/200	70000 – 140000	200	158	160	260	292	535	437	666	280	327 <sup>+0,5</sup>	370	59	16	330	362	315	130,5	90	408	12,29



# Curved Tooth Couplings SBL with HYGUARD® Safety Coupling BWL

Table of Dimensions No. 243 088

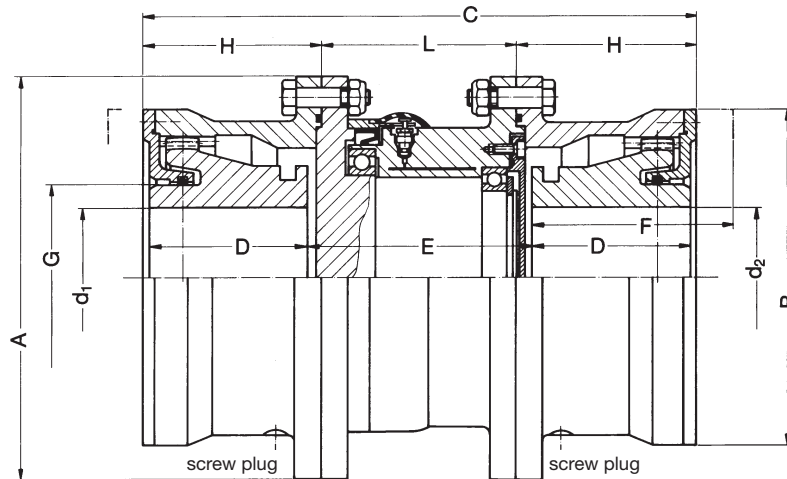

The HYGUARD® Safety coupling BWL in flanged design combined with the curved tooth coupling type SBL. Dimensions and features of the curved tooth coupling remain the same.

Double engagement type.

Max. angular offset per coupling half  $\pm 1.5$  degrees.

The curved tooth coupling SBL is suitable for oil and grease lubrication. Couplings of this series which are already in use can easily be retrofitted with the BWL safety coupling.

1) Values for complete coupling with max.  $d_1$  and  $d_2$

Dimensions are subject to change due to technical progress.

Type Combination SBL/BWL Size	Torque Range T ~ Nm	Bore $d_1, d_2$			Dimensions									Weight <sup>1)</sup> kg	Mass Moment of Inertia <sup>1)</sup> J kgm <sup>2</sup>
		rough mm	min mm	max mm	A mm	B mm	C mm	D mm	E mm	F mm	G mm	H mm	L mm		
<b>30/ 30</b>	400 – 800	10	12	32	118	92	190	50	87	75	45	55	80	10,4	0,0161
<b>40/ 40</b>	710 – 1420	20	22	46	145	115	227	60	104	90	60	68,5	90	18,6	0,045
<b>50/ 50</b>	1400 – 2800	20	22	58	165	135	267	70	124	110	75	78,5	110	27	0,083
<b>60/ 60</b>	2500 – 5000	26	28	70	200	160	288	80	122	120	90	91,5	105	41,8	0,181
<b>70/ 70</b>	4000 – 8000	26	28	78	220	178	314	90	128	130	100	102	110	54	0,283
<b>80/ 80</b>	5600 – 11200	30	32	92	240	196	344	100	138	150	120	112	120	69	0,433
<b>90/ 90</b>	8000 – 16000	30	32	100	270	225	382	110	154	170	130	126	130	101	0,803
<b>100/ 100</b>	11200 – 22400	53	55	110	280	240	412	120	164	180	140	136	140	116	1,01
<b>110/ 110</b>	14000 – 28000	63	65	120	310	265	442	130	174	190	155	146	150	151	1,64
<b>125/ 125</b>	22400 – 44800	73	75	138	340	295	500	150	190	215	175	170	160	202	2,81
<b>140/ 140</b>	31500 – 63000	83	85	156	390	325	540	165	200	230	200	185	170	281	4,57
<b>160/ 160</b>	45000 – 90000	118	120	180	435	370	606	190	214	270	230	213	180	387	8,15
<b>180/ 180</b>	63000 – 126000	138	140	200	480	415	673	220	229	300	260	239	195	530	13,49
<b>200/ 200</b>	90000 – 180000	158	160	225	545	465	748	245	250	340	290	269	210	745	24,24
<b>220/ 220</b>	125000 – 250000	158	160	250	580	510	818	270	278	360	355	294	230	910	33,11

# Curved Tooth Couplings SBLk with HYGUARD® Safety Coupling BWL



Table of Dimensions No. 243 089

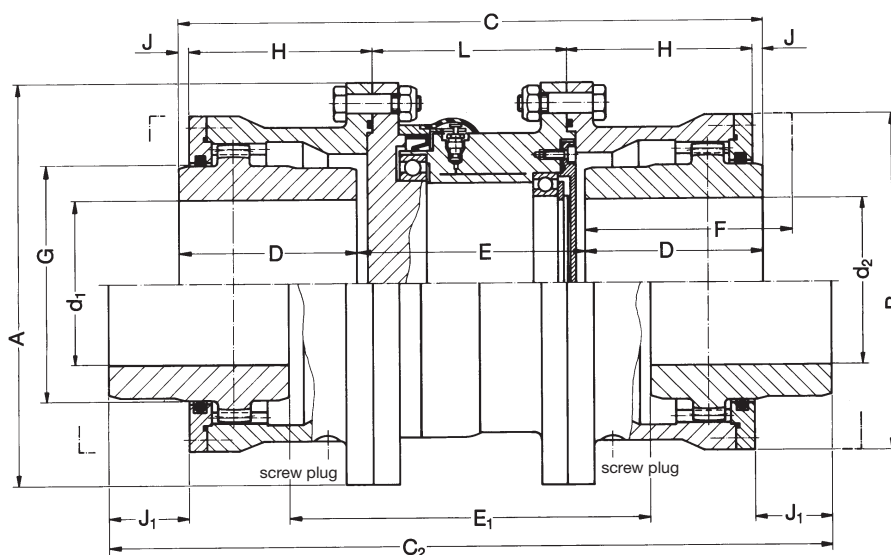

The HYGUARD® Safety coupling BWL in flanged design is combined with a curved tooth coupling SBLk. The coupling dimensions and double engagement feature are the same as for the normal spacer coupling. In comparison with the SBL version, this combination has a lower permissible angular offset

amounting to a maximum of  $\pm 0.75$  degrees per coupling half or, when using special versions, up to  $\pm 2$  degrees. The housing is tooth tip and flank centered. Curved tooth couplings of the SBLk series are designed for grease lubrication. Couplings already in use can easily be retrofitted with the BWL safety coupling.

1) Values for complete coupling with max.  $d_1$  and  $d_2$

Dimensions are subject to change due to technical progress.

Type Combination SBLk/BWL Size	Torque Range T ~ Nm	Bore $d_1, d_2$			Dimensions													Weight <sup>1)</sup> kg	Mass Moment of Inertia <sup>1)</sup> J kgm <sup>2</sup>
		rough mm	min mm	max mm	A mm	B mm	C mm	C <sub>2</sub> mm	D mm	E mm	E <sub>1</sub> mm	F mm	G mm	H mm	J mm	J <sub>1</sub> mm	L mm		
38/ 30	400 – 800	10	12	42	118	92	207	231	60	87	111	90	60	58,5	5	17	80	10,6	0,0163
48/ 40	710 – 1420	20	22	55	145	115	244	286	70	104	146	100	77	72	5	26	90	19,2	0,045
60/ 50	1400 – 2800	20	22	65	165	135	285	339	80	125	179	110	90	82	5,5	32,5	110	28,2	0,085
70/ 60	2500 – 5000	26	28	80	200	160	302	374	90	122	194	120	112,5	94,5	4	40	105	44	0,185
80/ 70	4000 – 8000	26	28	92	220	178	328	412	100	128	212	130	128,5	105	4	46	110	56	0,295
90/ 80	5600 – 11200	30	32	105	240	196	360	456	110	140	236	140	145	115	5	53	120	72	0,453
100/ 90	8000 – 16000	30	32	115	270	225	404	506	125	154	256	150	160,5	130	7	58	130	103	0,843
110/100	11200 – 22400	53	55	126	280	240	444	552	140	164	272	170	176	140	12	66	140	121	1,07
125/110	14000 – 28000	63	65	145	310	265	476	592	150	176	292	180	200,5	150	13	71	150	158	1,73
140/125	22400 – 44800	73	75	162	340	295	530	670	170	190	330	200	224,5	175	10	80	160	213	3,02
160/140	31500 – 63000	83	85	185	390	325	582	726	190	202	346	230	256,5	190	16	88	170	295	4,96
180/160	45000 – 90000	118	120	210	435	370	654	830	220	214	390	260	288,5	219	18	106	180	407	8,82
200/180	63000 – 126000	138	140	230	480	415	731	935	250	231	435	300	320,5	249	19	121	195	550	14,46
225/200	90000 – 180000	158	160	260	545	465	812	1036	280	252	476	330	362	279	22	134	210	772	25,74
250/220	125000 – 250000	158	160	280	580	510	1122	1122	300	522	522	350	400	282	164	164	230	942	35,01

# Curved Tooth Couplings LBLk with HYGUARD® Safety Coupling BWL



Table of Dimensions No. 243 090

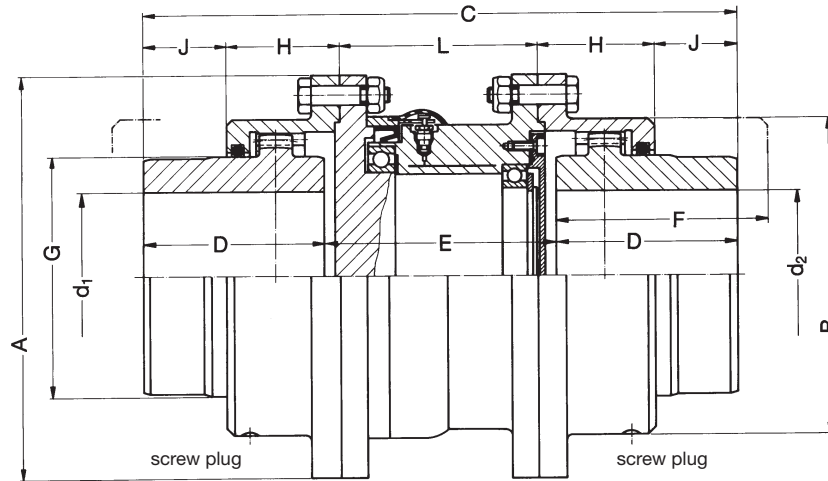

HYGUARD® Safety coupling BWL in flanged design with attached curved tooth coupling LBLk. This combination provides reliable protection against overload and is suitable for applications which do not require a shaft coupling with a complicated design. The permissible angular offset is  $\pm 0.75$

degrees per coupling half. The housing is tooth tip and flank centered. The standard version of the LBLk curved tooth coupling is grease-lubricated. The seal is provided by O-rings. LBLk curved tooth couplings already in use can be retrofitted with the HYGUARD® safety coupling BWL.

1) Values for complete coupling with max.  $d_1$  and  $d_2$

Dimensions are subject to change due to technical progress.

Type Combination <b>LBLk/BWL</b> Size	Torque Range T ~ Nm	Bore $d_1, d_2$			Dimensions										Weight <sup>1)</sup> kg	Mass Moment of Inertia <sup>1)</sup> J kgm <sup>2</sup>
		rough mm	min mm	max mm	A mm	B mm	C mm	D mm	E mm	F mm	G mm	H mm	J mm	L mm		
<b>38/ 30</b>	400 – 800	10	12	42	115	88	210	60	90	90	60	50,5	14,5	80	10,2	0,0154
<b>48/ 40</b>	710 – 1420	20	22	55	145	108	240	70	100	100	77	51	24	90	17,6	0,042
<b>60/ 50</b>	1400 – 2800	20	22	65	165	125	281	80	121	110	90	53,5	32	110	24,9	0,074
<b>70/ 60</b>	2500 – 5000	26	28	80	195	145	297	90	117	120	112,5	56	40	105	37,3	0,155
<b>80/ 70</b>	4000 – 8000	26	28	92	215	168	321	100	122	130	128,5	59	46,5	110	48	0,242
<b>90/ 80</b>	5600 – 11200	30	32	105	230	185	354	110	134	140	145	63,5	53,5	120	62	0,363
<b>100/ 90</b>	8000 – 16000	30	32	115	265	210	394	125	144	150	160,5	74	58	130	89	0,683
<b>110/100</b>	11200 – 22400	53	55	126	270	224	434	140	154	170	176	80,5	66,5	140	105	0,86
<b>125/110</b>	14000 – 28000	63	65	145	305	245	466	150	166	180	200,5	87,5	70,5	150	138	1,43
<b>140/125</b>	22400 – 44800	73	75	162	330	270	518	170	178	200	224,5	98,5	80,5	160	180	2,19
<b>160/140</b>	31500 – 63000	83	85	185	375	305	570	190	190	230	256,5	110,5	89,5	170	227	3,62
<b>180/160</b>	45000 – 90000	118	120	210	425	348	644	220	204	260	288,5	125	107	180	356	7,24
<b>200/180</b>	63000 – 126000	138	140	230	470	392	719	250	219	300	320,5	136	126	195	480	11,9
<b>225/200</b>	90000 – 180000	158	160	260	535	437	798	280	238	330	362	157,5	136,5	210	670	16,9

# Coupling Selection and Size Determination



**Table 1, Service Factor**

Machine	Service Faktor $K_1^{1)}$	Machine	Service Faktor $K_1^{1)}$	Machine	Service Faktor $K_1^{1)}$
<b>Excavators</b>		<b>Wood processing machines</b>		<b>Presses</b>	
Chain bucket excavators	2,0	Debarking drums	1,8	Folding presses	1,8
Travelling gears (caterpillar)	1,8	Planers	1,4	Briquetting presses	2,5
Travelling gears (rails)	1,6	Frame saws	1,4	Eccentric presses	2,0
Suction pumps	1,6	<b>Steel plants</b>		Forging presses	2,25
Bucket wheels	1,8	Blast furnace blowers	1,4	Brick moulding presses	2,5
Cutter heads	2,0	Converters	2,0	<b>Pumps</b>	
Slewing gears	1,4	Inclined blast furnace elevators	1,8	Centrifugal pumps (thin liquid)	1,25
Winches	1,6	Slag crushers	1,8	Centrifugal pumps (viscous liquid)	1,4
<b>Mining, stones</b>		<b>Cranes</b>		Reciprocating pumps (U 1 : 100)	1,8
Crushers	2,24	Luffing gears	1,25	Reciprocating pumps (U 2: 100-200)	1,6
Rotary kilns	1,8	Traversing gears	1,6	Plunger pumps	2,0
Mine ventilators	2,0	Hoists	1,4	Sludgers	1,4
Vibrators	1,6	Slewing gear	1,4	ELMO-Vacuum pumps	1,5
<b>Chemical plants</b>		Winches	1,25	<b>Textile machines</b>	
Agitators (thin liquid)	1,25	<b>Metal working</b>		Winders	1,6
Agitators (viscous liquid)	1,6	Press brakes	1,6	Printing and drying machines	1,6
Centrifuges (light)	1,4	Sheet straighteners	1,8	Tanning vats	1,6
Centrifuges (heavy)	1,8	Hammers	1,8	Calenders	1,6
<b>Conveyor plants</b>		Shears	1,6	Opening machines	1,6
Conveyors	1,8	Forging presses	1,8	Weaving looms	1,6
Slatted conveyors	1,6	Stamping machines	1,8	<b>Compressors</b>	
Belt conveyors (bulk materials)	1,4	<b>Mills</b>		Reciprocating compress. (U ≤ 1:100)	2,0
Slatted conveyors (piece goods)	1,6	Hammer mills	2,0	Reciprocating compressors (U = 1 : 100 – 200)	1,6
Pocket belt conveyors	1,25	Ball mills	2,0	Turbo compressors	1,6
Reels	1,8	Suspended roller mills	2,0	<b>Rolling mills</b>	
Bucket chain conveyors	1,4	Impact mills	2,0	Sheet metal shears	1,8
Rotary conveyors	1,4	Rod mills	2,0	Sheet turning machines	1,6
Elevators	1,4	Roller mills	2,0	Ingot slab mills	2,0
Bucket type flour elevators	1,25	<b>Food machinery</b>		Block conveyors	1,8
Lifts	1,8	Fillers	1,25	Block pushers	2,0
Apron conveyors	1,4	Kneading machines	1,4	Tape and wire reels	1,4
Screw conveyors	1,4	Packaging machines	1,25	Descalers	1,6
Steel belt conveyors	1,4	Sugar cane crushers	1,6	Sheet mills	1,8
Redler conveyors	1,4	Sugar cane cutters	1,6	Plate mills	2,0
<b>Blowers, ventilators</b>		Sugar cane mills	1,8	Cold rolling mills	2,0
Rotary piston blowers	1,4	Sugar beet cutters	1,6	Track-type tractors	1,6
Blowers (axial and radial)	1,25	Sugar beet washing plants	1,6	Billet shears	1,8
Cooling tower ventilators	1,4	<b>Paper machines</b>		Cooling beds	1,4
Induced draught fans	1,4	Couch presses	1,8	Transfer skids	1,4
Turbo-blowers	1,25	M. G. cylinders	2,0	Roller tables (light)	1,4
<b>Generators, converters</b>		Beating engines	1,6	Roller tables (heavy)	1,8
Frequency converters	2,24	Pulp grinders	1,8	Roller levellers	1,6
Generators	1,4	Calenders	1,6	Trimming shears	1,4
Welding generators	2,24	Wet presses	1,8	End shears	1,8
<b>Rubber and plastics machinery</b>		Opening machines	1,8	Looplifters	1,4
Extruders	1,6	Agitators	1,8	Roller control gears	1,4
Calenders	1,6	Suction presses	1,6		
Kneader machines	1,8	Suction couch rolls	1,8		
Mixers	1,8	Drying cylinders	2,0		
Rolling plants	1,8				

1) Service factor  $K_1$  for electric motor or turbine drives.  
For hydraulic motor or internal combustion engine drives factor  $K_1$  has to be multiplied by 1.1.

## Size determination

Condition for continuous power

$$\frac{P_N}{n} \cdot K_1 \leq \frac{P_{KN}}{n} \quad (\text{kW} \cdot \text{min})$$

Condition for continuous torque

$$\frac{P_N}{n} \cdot K_1 \cdot 9550 \leq \frac{P_{KN}}{n} \cdot 9550 \quad (\text{Nm})$$

$P_N$  = max. contin. power (kW)

$n$  = Operating speed (rpm)

$K_1$  = Service factor in accordance with Table 1

$$\frac{P_{KN}}{n} = \text{Rating in accordance with dim. table (kW} \cdot \text{min)}$$

With shear pin couplings, the max. cut-off torque corresponds to abt. 2,5 times the torque for normal operation.

Permissible additional loads: max. starting load of coupling =  $1,5 \cdot P_{KN}$

max. short-circuit load of coupling =  $3 \cdot P_{KN}$

If higher angular or radial misalignments occur in operation, it may be necessary to reduce the max. permissible operating speed. The max. permissible bore diameter is a further criterion for the determination of the coupling size. Therefore, having selected the coupling size on basis of the power, the bore needs to be verified, too. If the bore is not suitable to accommodate the existing shaft, a bigger coupling size has to be taken.

## Important note

The values specified in the dimension tables for the max. permissible bore only apply to key connections if the height of the keyway does not exceed the dimensions in accordance with DIN 6885. Please consult us if the keyway is higher.

# Curved Tooth Couplings Shear Pin Design Type HBBk

Table of Dimensions No. 243 196

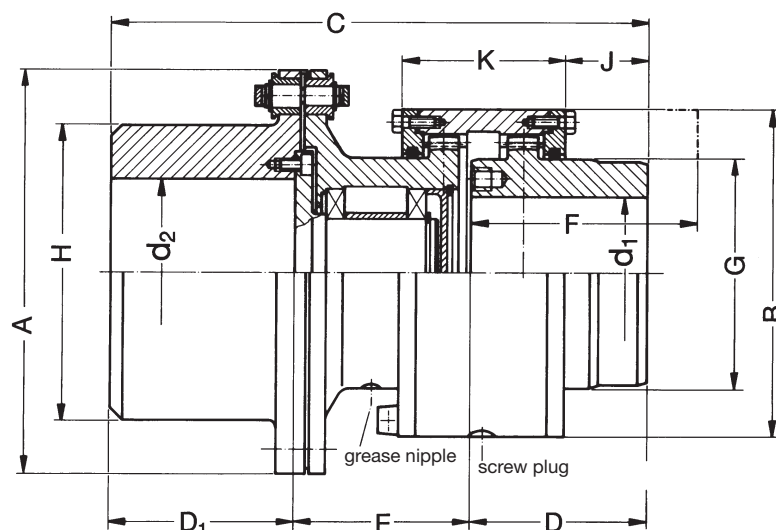

Dimensions are subject to change due to technical progress.

The couplings of construction series HBBk are equipped for grease lubrication.

Bores, chamfers, keyway dimensions and shear torque have to be specified with the order. The outer diameter A will be changed, if the shear torque so requires.

The max. cut-off torque is about 2,5 times the normal torque for continuous operation.

1) Values for complete coupling with max.  $d_1$ ;  $d_2$

Type HBBk	Norm. cont. duty $\frac{P_{KN}}{n}$ kW·min	Speed $n_{max.}$ rpm	Bore			Dimensions											Mass Moment of Inertia <sup>1)</sup> kgm <sup>2</sup>	Grease Quantity Coupling kg	Grease Quantity Ball Bearing kg	Weight <sup>1)</sup> kg
			$d_1$ ; $d_2$	$d_1$	$d_2$	A <sub>1</sub>	B	C	D	D <sub>1</sub>	E	F	G	H <sub>1</sub>	J	K				
Size			min.	max.	max.	mm	mm	mm	mm	mm	mm	mm	mm	mm	mm	mm	mm	mm	mm	
38	0,082	7500	12	42	50	125	92	203	60	60	83	90	60	80	5	86	0,007	0,06	0,02	5
48	0,146	6900	22	55	65	150	115	224	70	70	84	100	77	100	5	95,5	0,027	0,09	0,03	11,3
60	0,288	6300	22	65	75	180	135	260	80	80	100	110	90	120	5,5	108,5	0,049	0,15	0,06	17,9
70	0,50	5900	28	80	95	210	160	295	90	100	105	120	112,5	150	4	123	0,116	0,20	0,09	30
80	0,82	5400	28	92	105	230	178	321	100	110	111	130	128	170	46	94	0,177	0,12	0,17	39
90	1,14	5000	32	105	115	250	196	353	110	120	123	140	145	180	53	101	0,29	0,16	0,22	51
100	1,64	4700	32	115	130	280	225	378	125	130	123	150	160,5	205	58	116	0,53	0,24	0,27	71
110	2,30	4300	55	126	150	300	240	408	140	140	128	170	176	215	66	124	0,74	0,30	0,34	85
125	2,88	4000	65	145	160	325	265	436	150	150	136	180	200,5	230	71	134	1,12	0,41	0,44	107
140	4,60	3700	75	162	170	360	295	486	170	170	146	200	224,5	250	80	154	1,89	0,50	0,6	147
160	6,48	3200	85	185	200	410	325	550	190	190	170	230	256	290	88	173	3,36	0,65	1,0	206
180	9,24	2600	120	210	225	460	370	620	220	220	180	260	288,5	330	106	192	6,25	1,0	1,3	298
200	12,92	2400	140	230	250	525	415	703	250	250	203	300	320	360	121	218	11,4	1,3	1,8	424
225	18,4	2000	160	260	280	580	465	773	280	280	213	330	362	410	134	245	19,6	2,0	2,3	590



# Curved Tooth Couplings Shear Pin Design Type SBBk

Table of Dimensions No. 243 197

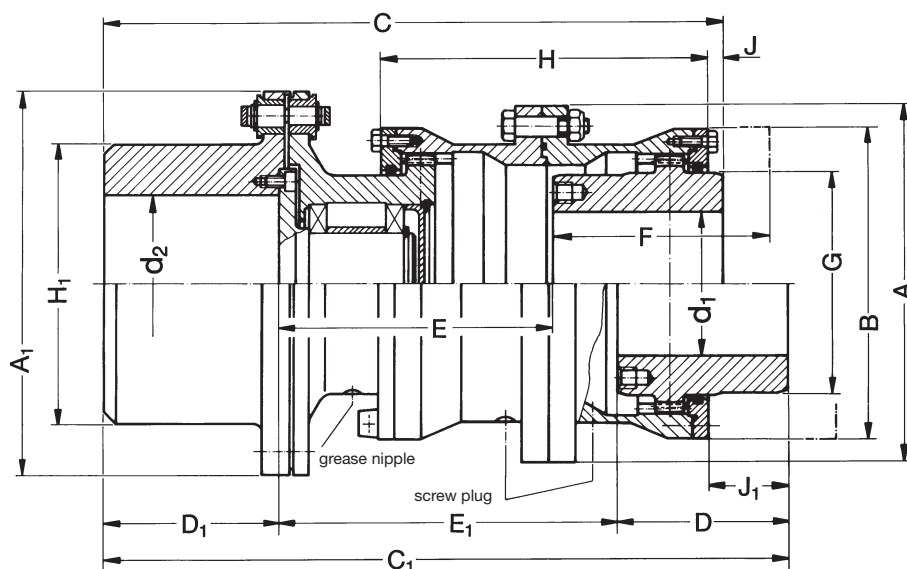

Hub arrangement I

Hub arrangement II

1) Values for complete coupling with max.  $d_1$ ;  $d_2$  bores

Type	Mass Moment of Inertia <sup>1)</sup>	Grease Quantity Coupling	Grease Quantity Ball Bearing	Weight <sup>1)</sup>
SBBk	kgm <sup>2</sup>	kg	kg	kg
Size				
38	0,011	0,085	0,02	6,0
48	0,029	0,09	0,03	13,2
60	0,061	0,17	0,06	20,6
70	0,146	0,25	0,09	35
80	0,244	0,35	0,17	48
90	0,379	0,40	0,22	60
100	0,697	0,60	0,27	85
110	0,943	0,75	0,34	102
125	1,47	1,0	0,44	130
140	2,42	1,3	0,6	175
160	4,50	1,6	1,0	254
180	8,12	2,6	1,3	362
200	14,35	3,3	1,8	505
225	25,47	4,8	2,3	715

The couplings of construction series SBBk are equipped for grease lubrication.

The max. cut-off torque is about 2,5 times the normal torque for continuous operation.

The structure of the SBBk series allows different arrangements for the hub in the housing, so that greater shaft distances can be bridged over. In case of taper bores, the enlarged E-dimension provides space for the use of shaft nuts.

Dimensions are subject to change due to technical progress.

Type	Norm. cont. duty	Speed	Bore			Dimensions														
			$d_1; d_2$	$d_1$	$d_2$	A	A <sub>1</sub>	B	C	C <sub>1</sub>	D	D <sub>1</sub>	E	E <sub>1</sub>	F	G	H	H <sub>1</sub>	J	J <sub>1</sub>
SBBk	$\frac{P_{KN}}{n}$	$n_{max.}$	min.	max.	max.	mm	mm	mm	mm	mm	mm	mm	mm	mm	mm	mm	mm	mm	mm	mm
Size	kW·min	rpm	mm	mm	mm	mm	mm	mm	mm	mm	mm	mm	mm	mm	mm	mm	mm	mm	mm	mm
38	0,082	7500	12	42	50	118	125	92	232	244	60	60	112	124	90	60	115	80	5	17
48	0,146	6900	22	55	65	145	150	115	264,5	285,5	70	70	124,5	145,5	100	77	135	100	5	26
60	0,288	6300	22	65	75	165	180	135	306,5	333,5	80	80	146,5	173,5	110	90	155	120	5,5	32,5
70	0,50	5900	28	80	95	200	210	160	350	386	90	100	160	196	120	112,5	178	150	4	40
80	0,82	5400	28	92	105	220	230	178	383	425	100	110	173	215	130	128	198	170	4	46
90	1,14	5000	32	105	115	240	250	196	422	470	110	120	192	240	140	145	218	180	5	53
100	1,64	4700	32	115	130	270	280	225	455	506	125	130	200	251	150	160,5	244	205	7	58
110	2,30	4300	55	126	150	280	300	240	494	548	140	140	214	268	170	176	264	215	12	66
125	2,88	4000	65	145	160	310	325	265	528	586	150	150	228	286	180	200,5	284	230	13	71
140	4,60	3700	75	162	170	340	360	295	592	662	170	170	252	322	200	224,5	330	250	10	80
160	6,48	3200	85	185	200	390	410	325	665	737	190	190	285	357	230	256,5	360	290	16	88
180	9,24	2600	120	210	225	435	460	370	756	844	220	220	316	404	260	288,5	416	330	18	106
200	12,92	2400	140	230	250	480	525	415	859	961	250	250	359	461	300	320,5	476	360	19	121
225	18,4	2000	160	260	280	545	580	465	948	1060	280	280	388	500	330	362	532	410	22	134

# Curved Tooth Couplings Shear Pin Design Type SBBLk



Table of Dimensions No. 243 198

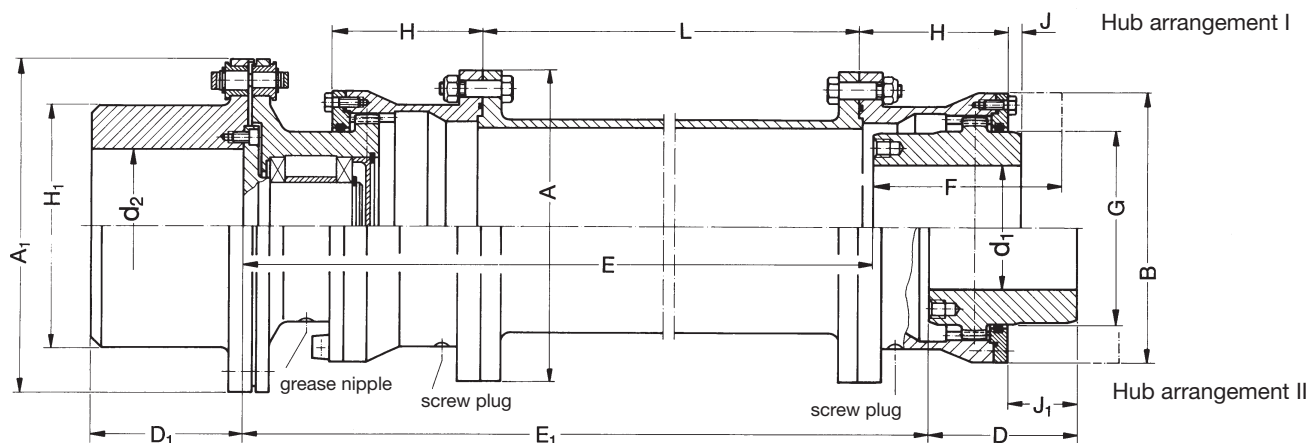

1) Values for complete coupling with max.  $d_1$ ;  $d_2$  bores without spacer

Type	Mass Moment of Inertia <sup>1)</sup>	Grease Quantity Coupling	Grease Quantity Ball Bearing	Weight <sup>1)</sup>
SBBLk	kgm <sup>2</sup>	kg	kg	kg
Size	kgm <sup>2</sup>	kg	kg	kg
38	0,011	0,085	0,02	6,0
48	0,030	0,09	0,03	13,7
60	0,062	0,17	0,06	21,1
70	0,148	0,25	0,09	35,7
80	0,248	0,35	0,17	48,5
90	0,39	0,40	0,22	61,5
100	0,72	0,60	0,27	88
110	0,97	0,75	0,34	104
125	1,50	1,0	0,44	132
140	2,71	1,3	0,6	178
160	4,56	1,6	1,0	258
180	8,34	2,6	1,3	370
200	14,65	3,3	1,8	510
225	25,48	4,8	2,3	710

The couplings of construction series SBBLk are equipped for grease lubrication.

The max. cut-off torque is about 2,5 times the normal torque for continuous operation.

The structure of the SBBLk series allows different arrangements for the hub in the housing, so that greater shaft distances can be bridged over. In case of taper bores, the enlarged E-dimension provides space for the use of shaft nuts.

Dimensions are subject to change due to technical progress.

Type SBBLk	Norm. duty $\frac{P_{KN}}{n}$ kW-min	Speed cont. $n_{max}$ rpm	Bore			Dimensions												
			$d_1; d_2$	$d_1$	$d_2$	A	A <sub>1</sub>	B	D	D <sub>1</sub>	F	G	H	H <sub>1</sub>	J	J <sub>1</sub>	L	L
			min. mm	max. mm	max. mm	mm	mm	mm	mm	mm	mm	mm	mm	mm	mm	mm	mm	mm
38	0,082	7500	12	42	50	118	125	92	60	60	90	60	58,5	80	5	17	E-115	E <sub>1</sub> -127
48	0,146	6900	22	55	65	145	150	115	70	70	100	77	72	100	5	26	E-132,5	E <sub>1</sub> -153,5
60	0,288	6300	22	65	75	165	180	135	80	80	110	90	82	120	5,5	32,5	E-155,5	E <sub>1</sub> -182,5
70	0,50	5900	28	80	95	200	210	160	90	100	120	112,5	94,5	150	4	40	E-171	E <sub>1</sub> -207
80	0,82	5400	28	92	105	220	230	178	100	110	130	128	105	170	4	46	E-185	E <sub>1</sub> -227
90	1,14	5000	32	105	115	240	250	196	110	120	140	145	115	180	5	53	E-204	E <sub>1</sub> -252
100	1,64	4700	32	115	130	270	280	225	125	130	150	160,5	130	205	7	58	E-216	E <sub>1</sub> -267
110	2,30	4300	55	126	150	280	300	240	140	140	170	176	140	215	12	66	E-230	E <sub>1</sub> -284
125	2,88	4000	65	145	160	310	325	265	150	150	180	200,5	150	230	13	71	E-244	E <sub>1</sub> -302
140	4,60	3700	75	162	170	340	360	295	170	170	200	224,5	175	250	10	80	E-272	E <sub>1</sub> -342
160	6,48	3200	85	185	200	390	410	325	190	190	230	256,5	190	290	16	88	E-305	E <sub>1</sub> -377
180	9,24	2600	120	210	225	435	460	370	220	220	260	288,5	219	330	18	106	E-338	E <sub>1</sub> -426
200	12,92	2400	140	230	250	480	525	415	250	250	300	320,5	249	360	19	121	E-381	E <sub>1</sub> -483
225	18,40	2000	160	260	280	545	580	465	280	280	330	362	279	410	22	134	E-414	E <sub>1</sub> -526

# TORLOC® Clamping Elements



Table of Dimensions No. 243 199

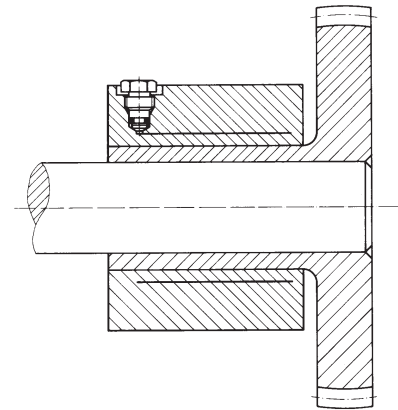
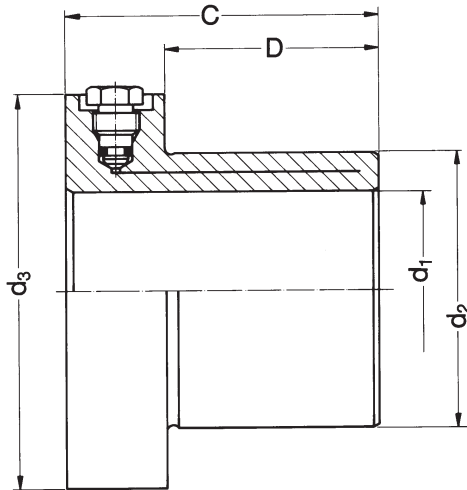

● Note

Higher axial forces occurring with the clamping connection may affect the permissible torque. In such cases, a reduction factor has to be taken into consideration for the calculations.

Comparison values are given in the table.

Example: SP 30

$F_{KA}$  up to 4500 N;  $f = 1$   
 > 4500 N < 9000 N;  $f = 0,9$   
 > 9000 N to 13500 N;  $f = 0,8$

1) max. permissible torque. The starting and peak torques must not exceed this value.  
 2) Please contact us in case of higher axial forces.

Type SP	Torque <sup>1)</sup> $T_{KS}$ ~ Nm	Axial Force $F_{KA}$ N			Dimensions					Weight kg	Mass Moment of Inertia J kgm <sup>2</sup>
		f = 1	f = 0,9	f = 0,8	d <sub>1</sub> mm	d <sub>2</sub> mm	d <sub>3</sub> mm	C mm	D mm		
30	390	4500	9000	13500	30	40	85	66	36	1,33	0,0012
35	610	6000	12000	18000	35	45	91	71	41	1,50	0,0016
40	900	7800	15600	23400	40	52	96	77	47	1,72	0,0021
45	1370	10500	21000	31500	45	58	103	83	53	2,03	0,0028
50	1620	11200	22400	33600	50	65	109	87	57	2,35	0,0036
60	2900	16900	33800	50700	60	75	120	95	65	2,81	0,0054
70	4000	20000	40000	60000	70	90	135	104	74	3,92	0,0095
80	6700	29000	58000	87000	80	100	144	120	90	4,65	0,0131
90	9800	38000	76000	114000	90	110	155	132	102	5,47	0,0182
100	11900	41000	82000	123000	100	125	170	146	108	8,18	0,0335
110	13600	43000	86000	129000	110	140	188	144	109	10,04	0,0497
120	20500	59000	118000	177000	120	150	196	171	133	12,24	0,0678
130	26800	70000	140000	210000	130	160	205	182	144	13,62	0,0844
140	33800	83000	166000	249000	140	170	215	190	152	14,95	0,1042
150	41000	95000	190000	285000	150	180	225	200	162	16,48	0,1281
160	47500	100000	200000	300000	160	200	233	225	180	23,95	0,2105
170	53000	108000	216000	324000	170	210	243	221	176	24,85	0,2425
180	57000	111000	220000	333000	180	225	261	221	176	29,68	0,3298
190	81000	148000	296000	444000	190	240	273	270	222	39,95	0,4906
200	92000	160000	320000	480000	200	250	283	270	222	41,90	0,5598
220	113000	178000	256000	534000	220	270	301	270	222	45,09	0,7096

**Size determination**

$$T_S \leq T_{KS} \cdot f$$

$$F_a \leq F_{KA}$$

$T_S$  = existing max. peak or starting torque

$T_{KS}$  = admissible torque acc. to table

f = factor for higher axial forces acc. to table

$F_a$  = existing axial force

$F_{KA}$  = admissible axial force acc. to table

**Fig. 1**

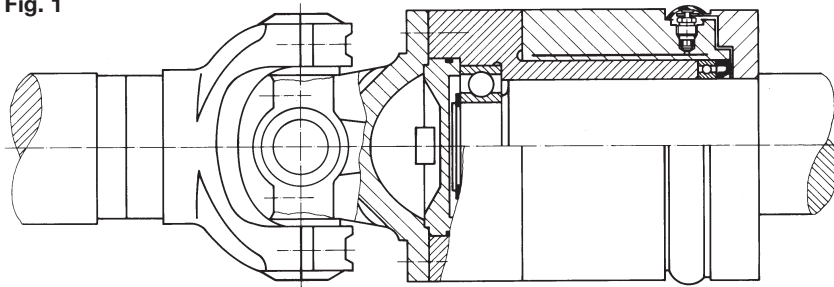

**Fig. 1** Cardan shaft / HDW

**Fig. 2** Remote release

**Fig. 3** Slip monitoring

**Fig. 4** SBGk/BW with intermediate shaft

**Fig. 2**

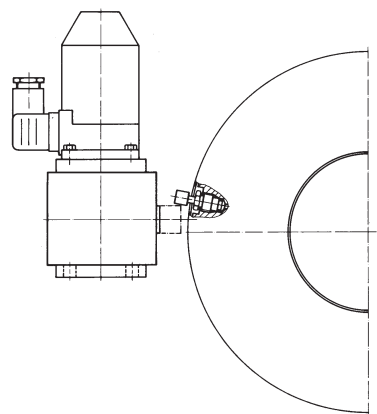

**Fig. 3**

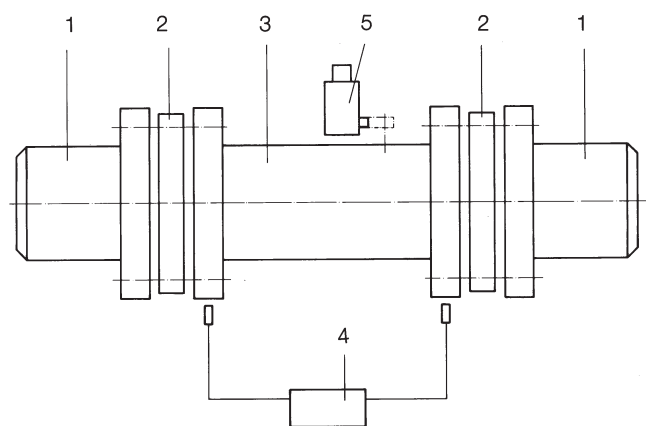

Details of Fig. 3

1 clamping element

2 Raflex® Steel disk or curved  
tooth coupling

3 safety coupling

4 slip monitoring

5 remote release

**Fig. 4**

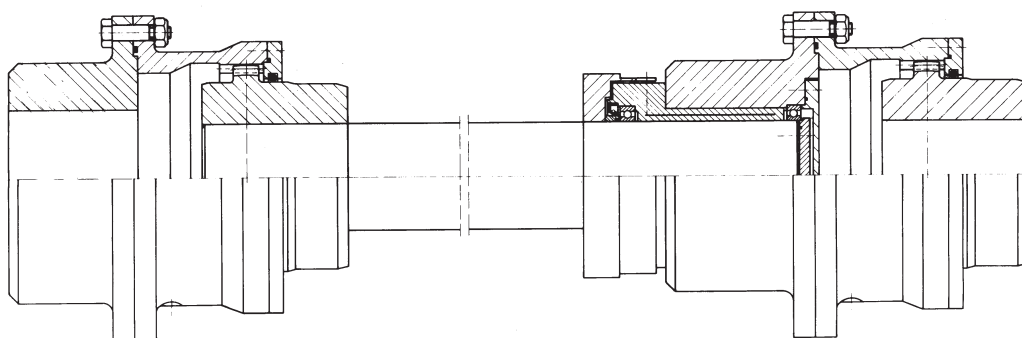

# Slip monitoring



## Slip monitoring SKS 03

The slip monitor SKS 03 is available for monitoring the operation of the safety couplings. It operates on the basis of differential speed detection and is a meaningful addition to the Renk Tacke safety system. In addition to continuous monitoring, it offers the advantage of providing the quickest information on changes in the operating state.

An alarm is issued directly after release of the safety coupling due to an overload. If this is coupled appropriately to the machine control, it can also trigger off other devices such as automatic cut-off. This signifies additional protection of machines and systems. Slip monitors can be integrated into the overall control as electronic components. This enables the inclusion of safety couplings, also in combination with curved tooth couplings, into process control and monitoring.

## Function

The slip monitor SKS 03 continuously checks the rotary pulses on both sides of the safety coupling. During normal operation, the drive and output drive sides constantly supply completely synchronous values. If a speed difference should occur, the timing sequence of the two pulses also inevitably changes. This may happen due to the slipping of a friction coupling, or on release of the safety coupling. The logic circuit reacts to

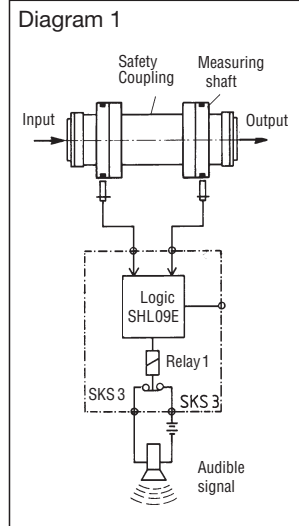

this by causing relay 1 to drop; refer to diagram 1 for the functions. It triggers off an alarm or other devices.

Amongst others, proximity switches which must conform to NAMUR regulations can be used as pulse transmitters. Proximity switches operate without contact and therefore involve no wear whatever. The control pulses are triggered by bores, webs, screw heads or interruptions in the surface. Scanning can take place radially or axially. However, it is important to ensure that identical markings of identical quantity are distributed on the circumference on either sides of the measuring unit. Only this will ensure synchronous control. The unit's principle of operation can be recognized easily with reference to the various pulse diagrams in diagram 2. Due to its conception, this unit is equally suitable for monitoring friction couplings as well as safety couplings with shearing elements. As far as this is concerned the safety cou-

Diagram 2

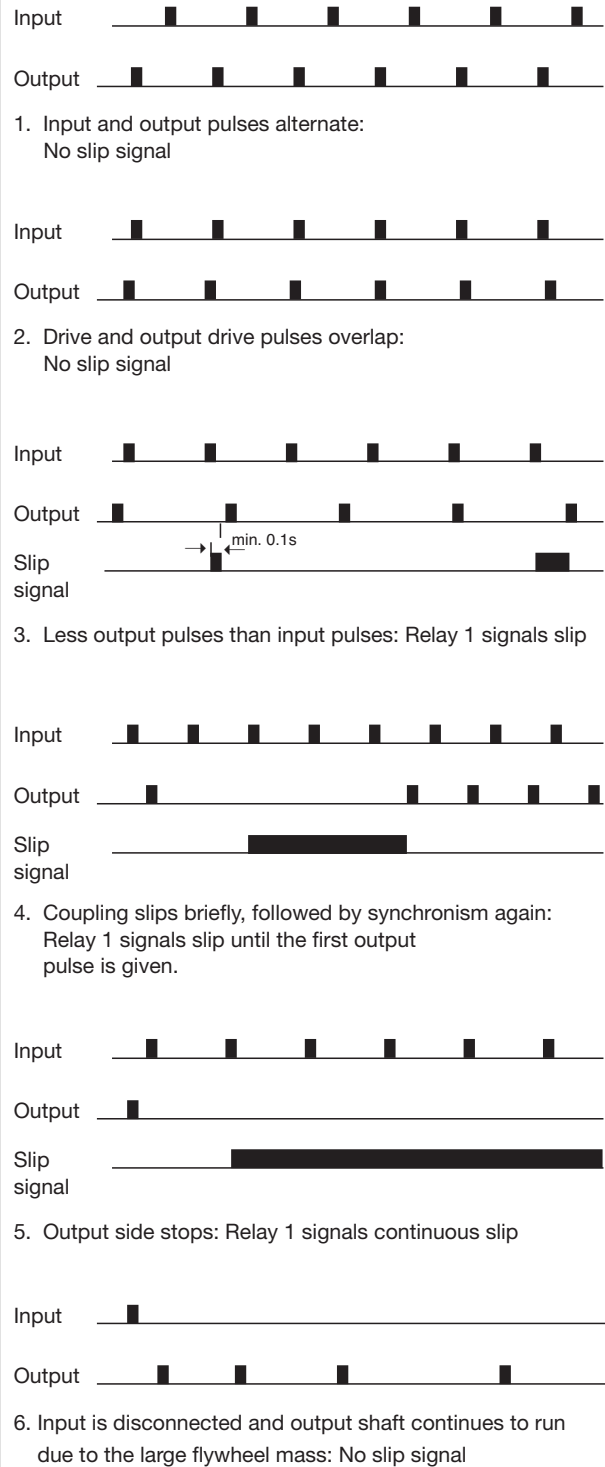

plings are equivalent to couplings with shearing elements. Diagram 5 "continuous slip" applies after release.

Dimensions are subject to change due to technical progress.



# Assembly Accessories



Photo - top  
Contents of Service Box RT 100  
Photo - middle  
Contents of Service Box RT 2000  
Photo - bottom  
Pneumatically operated motor pump

## Service-Box

All the required tools to facilitate the assembly and commissioning of the safety couplings are included in a solid Service Box. The Service Box contains a high-pressure pump with hand lever (RT 100). It works like a piston pump and is equipped with a pressure gauge. The pump is also provided with a pressure valve so that the operating pressure can be pre-set to the required value. This offers particular advantages, if several safety couplings are operating in one plant at the same service pressure. The large Service Box also includes a high-pressure pump with hand lever (RT 2000), which is particularly

suitable for coupling types as of size 200. The number of the required Service Boxes depends exclusively on the operational needs. It may well be possible that one box is sufficient though several safety couplings are installed in one plant. On the other hand, the spatial distance between the individual plant components may call for an additional box, or even more boxes. A further criterion is the number of cut-off sequences which are to be expected due to overload. It is recommended to use the larger hand pump RT 2000 or a motor pump for very big couplings or in case of frequent changes of the clamping elements.

### Injector connection (old)

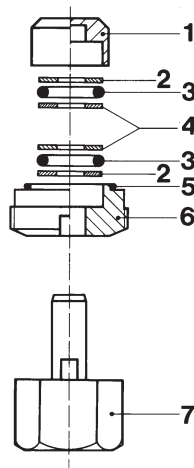

- 1 cover
- 2 back-up ring
- 3 O-ring
- 4 distance ring
- 5 O-ring
- 6 screw
- 7 mounting tool

### Injector connection (new)

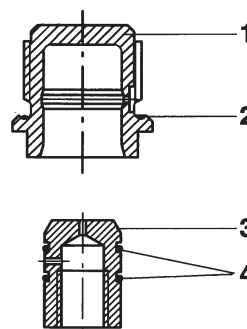

- 1 body
- 2 O-ring
- 3 screw plug
- 4 O-ring

### Fitting for Pump RT 100

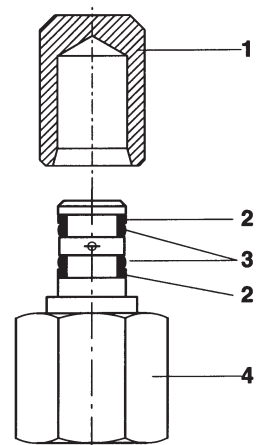

- 1 protection cap
- 2 back-up ring
- 3 O-ring
- 4 body

# Applications



## For Test Stands

Car manufacturers use HYGUARD® Safety Couplings in their gearbox test stands. Due to the rapid and safe decoupling of the gearbox in the event of cut-off, this safety coupling has proved itself as an extremely effective protection for the valuable measuring facilities. The test equipment consists of an electric motor, an electric brake and the gearbox to be tested. The measuring equipment is integrated in the test set-up. The units to be tested are started up to the individual gear speeds with gradually increasing load.

In case of failures, the gearbox has to be immediately disconnected from the motor to avoid all further damages. The precise cause for the failure can only be determined in this way. Due to the high speeds involved, only safety couplings with roller bearings are used in such installations.

Technical details:

Safety coupling HWF 90 / Release torque 7.000 Nm  
Speed 4.000 rpm / Shaft diameter 90 mm

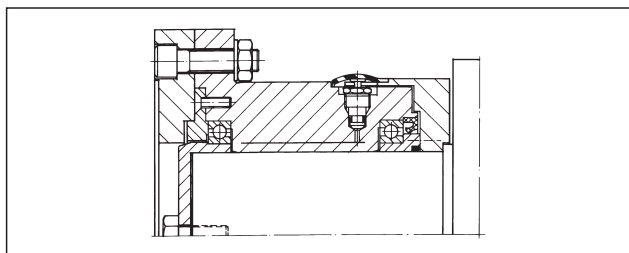

## For rolling mills

Billet mills place particularly high demands on torque-limiting couplings because the drives involved are always of the heavy-duty type.

In case of overload or sudden standstill of the rolls due to blocking, the coupling releases immediately.

A damage to the pinion stand caused by the high mass moment of inertia of the driving motor is thus prevented.

Technical details:

Safety coupling HDW 550 / Release torque 1.500.000 Nm  
Speed 90 rpm / Shaft diameter 402 mm

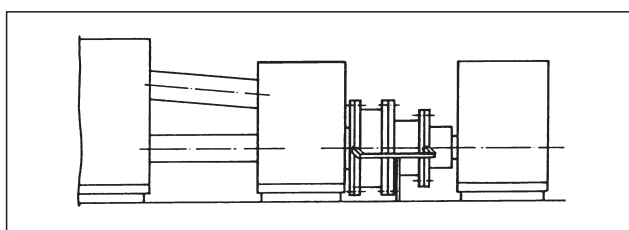

## For conveying system

Numerous manufacturers of such conveying systems have been successfully using the safety couplings for many years. These couplings do not contain any movable parts, and are well suitable for use under rough service conditions. The type HWF 170 is installed in worm conveyors.

Technical details:

Safety coupling HWF 170  
Release torque 55.000 Nm  
Speed 550 rpm  
Shaft diameter 140 mm

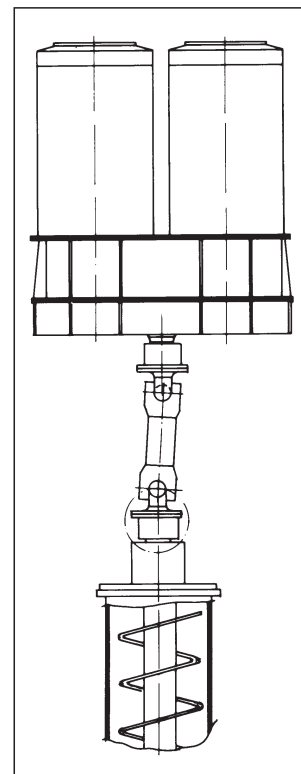

## For utility vehicles

HYGUARD® safety couplings are installed in special duty vehicles which are suitable for road and rail.

For the service as rail vehicle, the HYGUARD® safety coupling serves as protection of the auxiliary drive.

Technical details:

Safety coupling HW 60  
Release torque 3.400 Nm  
Speed 950 rpm  
Shaft diameter 60 mm





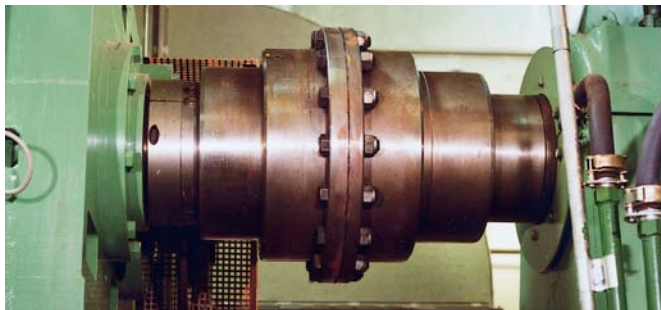

1

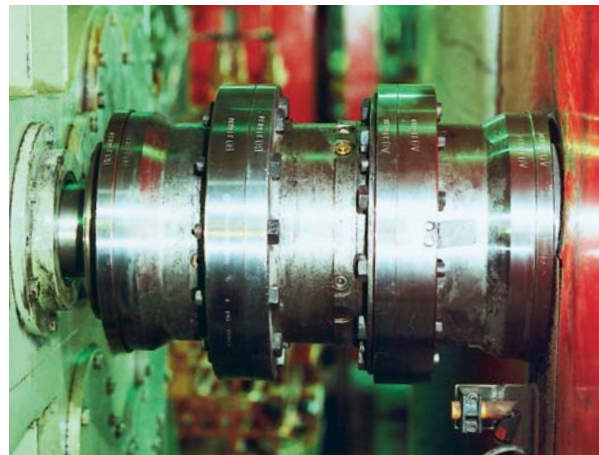

3



2

1 HYGUARD® safety coupling in four high-stand reversing mill shown on photo 4

2 Twenty roll-cold rolling mill with HYGUARD® safety coupling in the main drive between motor and gearbox

3 HYGUARD® safety coupling in the twenty roll-cold rolling mill shown on photo 2

4 Four high-stand reversing mill with HYGUARD® safety coupling in the main drive between motor and pinion stand gearbox



4

# Further products of our range



1

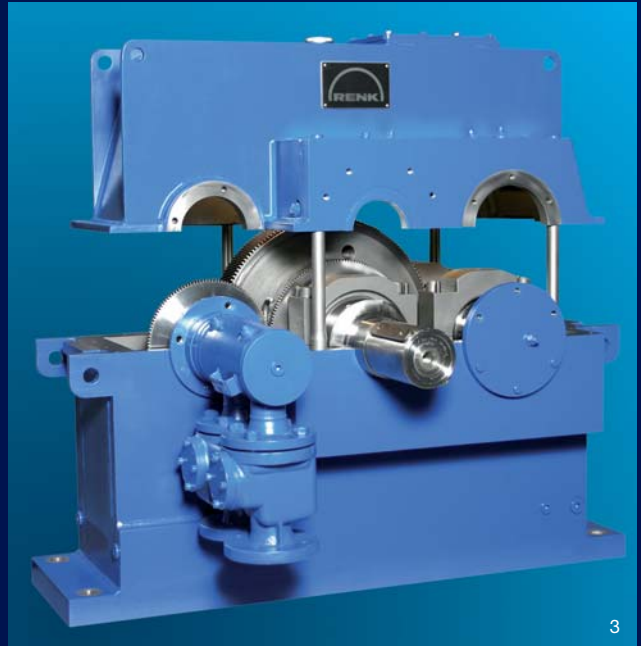

3



2



4

1 Curved tooth coupling Type SB

3 Curved tooth coupling Type SBk

2 High-speed gearbox Type THGD-900

4 Raflex® flexible steel disk coupling  
Type MTP acc. to API 610



RENK Aktiengesellschaft  
Rheine works  
Rodder Damm 170  
D-48432 Rheine / Germany

Telephone: ++49 5971 790-0  
Telefax: ++49 5971 790 208 and 790 256  
E-mail: [info.rheine@renk.biz](mailto:info.rheine@renk.biz)  
Internet: <http://www.renk.eu>