

GEARex® FA, FB and FAB All-steel gear couplings

Coupling in accordance with AGMA 9008-B00, high power density

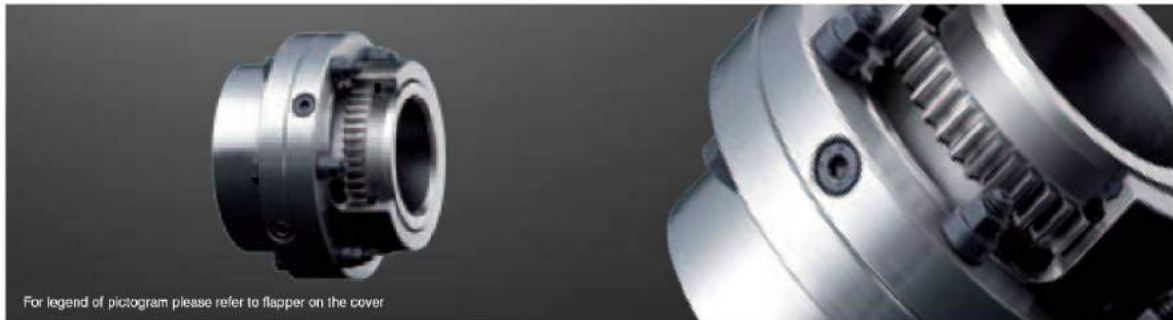

For legend of pictogram please refer to flapper on the cover

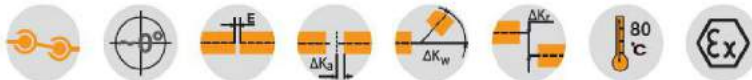

Dimensions																		
Size	Pilot bore	Max. finish bore			Dimensions [mm]													Grease feeding [dm ³] ²⁾
		d ₁ ; d ₂	l ₁ ; l ₂	Hub lengthened max l ₁ ; l ₂	EFA	EFB	E _{FAB}	L _{FA}	L _{FB}	L _{FAB}	L ₃	D	D _{A1}	D _{A2}	F ¹⁾	d ₃ ¹⁾		
10	26	50	43	105	3	21	12	89	107	98	55	87	111	84	74	52	0,02	
15	26	84	50	115	3	15	9	103	115	109	59	87	152	107	84	68	0,04	
20	31	80	62	130	3	31	17	127	155	141	79	108	178	130	104	85	0,08	
25	38	98	76	150	5	29	17	157	181	169	93	130	213	158	123	110	0,12	
30	44,5	112	90	170	5	33	19	185	213	199	109	153	240	182	148	130	0,18	
35	46	133	105	185	6	40	23	216	250	233	128	180	280	214	172	150	0,22	
40	52	158	120	215	6	42	24	246	282	264	144	214	318	250	192	175	0,35	
45	80	172	135	245	8	50	29	278	320	299	164	233	347	274	216	190	0,45	
50	80	192	150	295	8	56	32	308	356	332	182	260	390	309	241	220	0,70	
55	90	210	175	300	8	70	39	356	420	389	214	283	425,5	334	275	250	0,90	
60	100	232	190	305	8	84	46	388	464	426	236	312	457	365,5	316	265	1,15	
70	100	276	220	310	10	76	43	450	516	483	283	371	527	425	380	300	1,50	

Technical data										
Size	Torque [Nm]		max. Drehzahl [1/min]	Weight with max. bore [kg]			Mass moment of inertia with max. bore [kgm ²]	Dowel screw (10.9)		
	T _{KN}	T _{KN} (42CrMo4)		Sleeve	Hub	Total		z	M	T _A [Nm]
10	930	1580	8500	0,75	0,55	2,73	0,00436	6	M6	15
15	2000	3300	7700	1,88	1,12	6,38	0,01894	8	M8	36
20	3500	6300	6900	2,60	2,09	9,94	0,04000	6	M10	72
25	6500	11000	6200	4,43	3,56	16,83	0,09749	6	M12	125
30	10000	17400	5800	5,83	6,18	25,21	0,18060	8	M12	125
35	17000	28800	5100	9,71	9,87	41,25	0,41419	8	M14	200
40	28500	48500	4500	11,88	16,07	58,14	0,75535	8	M14	200
45	37000	62000	4000	15,72	21,42	77,08	1,17590	10	M14	200
50	51000	86000	3750	25,66	29,59	114,40	2,24991	8	M18	430
55	65000	110000	3550	31,52	40,30	150,41	3,45102	14	M18	430
60	85000	145000	3400	32,82	52,96	177,44	4,16734	14	M18	430
70	135000	240000	3200	43,52	85,77	268,20	9,32429	16	M20	610

■ = Standard

¹⁾ Space required to align the coupling or replace the sealing ring

²⁾ Grease feeding for each coupling half

Ordering example:	GEARex® FA 10	d ₁ Ø50	d ₂ Ø50
	Size and type of coupling	Finish bore with keyway to DIN 6885 sheet 1	Finish bore with keyway to DIN 6885 sheet 1

Type FA

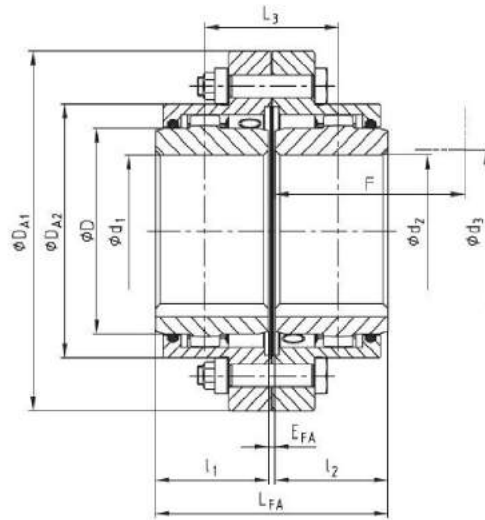

Type FB

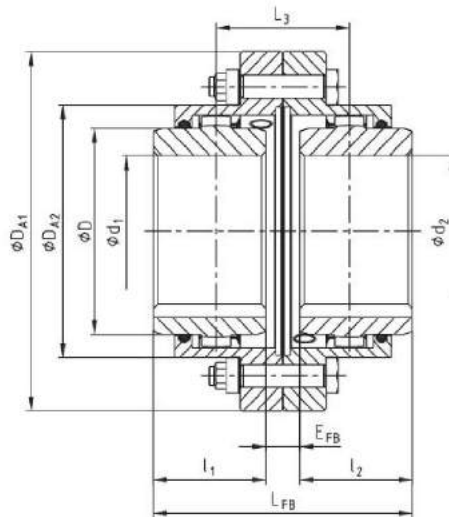

Type FAB

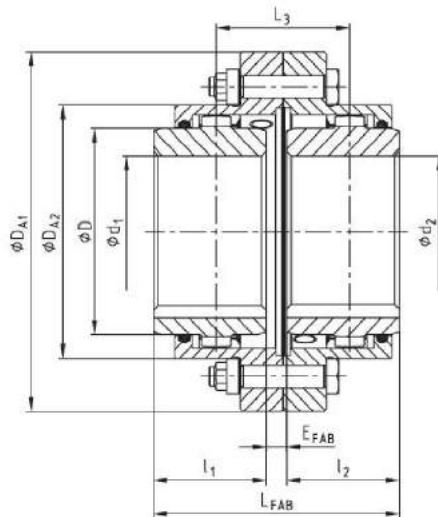

GEARex® DA, DB and DAB All-steel gear couplings

Easy to assemble, high power density



Dimensions																	
Size	Pilot bore	Max. finish bore		Dimensions [mm]													Grease feeding [dm ³] ²⁾
		d ₁ :d ₂	l ₁ :l ₂	E _{DA}	E _{DB}	E _{DAB}	L _{DA}	L _{DB}	L _{DAB}	L ₃	D	DA ₁	DA ₂	F ¹⁾	d ₃ ¹⁾		
20	31	80	62	3	31	17	133	155	144	79	108	187	146	105	85	0,08	
25	38	98	76	5	29	17	157	181	169	93	130	220	172	115	105	0,12	
30	44,5	112	90	5	33	19	185	213	199	109	153	248	182	140	120	0,18	
35	46	133	105	6	40	23	216	250	233	128	180	285	214	165	145	0,22	
40	52	158	120	6	42	24	246	282	264	144	214	335	250	180	160	0,35	
45	80	172	135	8	50	29	278	320	299	164	233	358	294	195	185	0,45	
50	80	192	150	8	56	32	388	356	332	182	260	390	309	215	205	0,70	
55	90	210	175	8	70	39	358	420	389	214	283	425,5	348	240	220	0,90	
60	100	232	190	8	84	46	388	464	426	236	312	457	380	260	245	1,15	
70	100	278	220	10	76	43	450	516	483	263	371	527	445	300	290	1,50	
80	140	300	280	10	50	30	570	610	590	310	394	545	475	340	310	2,50	
85	180	325	292	13	53	33	597	637	617	325	430	585	515	352	330	3,00	
90	180	350	305	13	83	48	623	693	658	353	464	640	560	365	360	4,00	
100	220	390	330	13	93	53	673	753	713	383	512	690	612	390	400	5,00	
110	220	420	350	20	296	158	720	996	858	508	560	765	665	410	420	6,00	
120	260	450	420	25	421	223	864	1261	1063	643	608	825	720	480	470	7,50	
130	300	500	440	25	415	220	905	1295	1100	660	684	950	805	520	520	9	
140	380	580	460	20	430	225	940	1350	1145	685	750	1010	875	570	590	12	
150	460	660	520	30	480	245	1070	1500	1285	765	850	1140	975	630	670	15	

Technical data										
Size	Torque [Nm]		Max. speed [1/min]	Weight with max. bore [kg]			Mass moment of inertia with max. bore [kgm ²]	Dowel screw (10.9)		
	T _{KN}	T _{KN} (42CrMo4)		Sleeve	Hub	Total		z	M	T _A [Nm]
20	3500	6300	6900	3,6	2,1	12,8	0,056	6	M10	72
25	6500	11000	6200	5,5	3,6	20,3	0,125	6	M12	125
30	10000	17400	5800	6,9	6,2	28,9	0,219	8	M12	125
35	17000	28800	5100	11,2	9,8	46,6	0,488	8	M14	200
40	28500	48500	4500	16,3	15,9	70,9	1,011	8	M14	200
45	37000	62000	4000	20,2	21,4	90,7	1,482	10	M14	200
50	51000	86000	3750	27,0	29,5	123,5	2,474	8	M18	430
55	65000	110000	3550	32,6	40,2	159,1	3,714	14	M18	430
60	85000	145000	3400	32,0	52,8	184,4	4,810	14	M18	430
70	135000	240000	3200	43,8	85,5	280	9,907	16	M20	610
80	175000	300000	1900	64	117	362	14,214	18	M20	610
85	225000	380000	1900	75	148	446	20,320	20	M20	610
90	290000	500000	1700	101	183	568	31,036	20	M24	1000
100	380000	650000	1600	117	232	698	45,358	24	M24	1000
110	480000	820000	1450	140	295	940	73,880	20	M30	1700
120	620000	1050000	1350	188	430	1312	118,40	24	M30	1700
130	-	1450000	1150	319	603	1954	226,732	20	M36	2800
140	-	1950000	1050	373	758	2391	328,567	24	M36	2800
150	-	2750000	950	475	983	3069	540,298	30	M36	2800

■ = Standard

¹⁾ Space required to align the coupling or replace the sealing ring

²⁾ Grease feeding for each coupling half

Ordering example:	GEARex® DA 80	d ₁ Ø300	d ₂ Ø300
	Size and type of coupling	Finish bore with keyway to DIN 6885 sheet 1	Finish bore with keyway to DIN 6885 sheet 1

Type DA

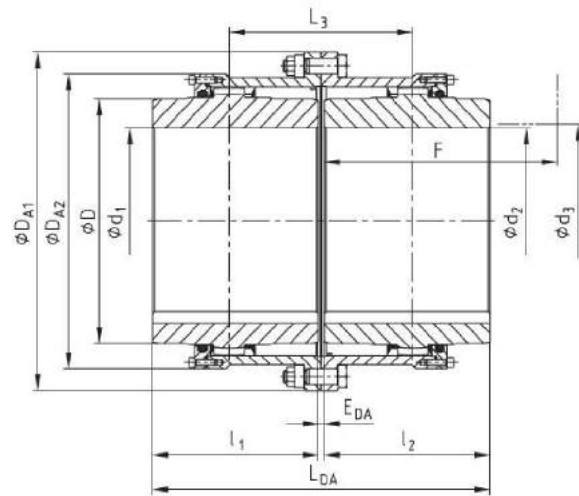

Type DB

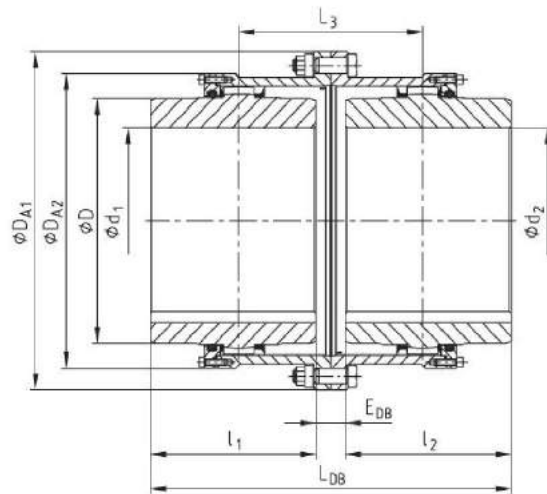

Type DAB

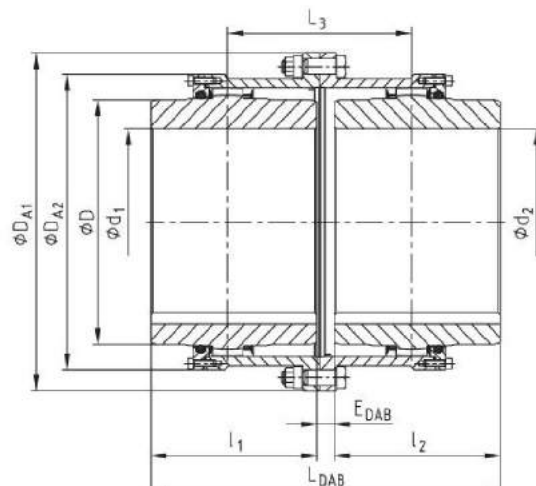

GEARex® FH and DH

All-steel gear coupling

Large shaft distance dimension, high power density



For legend of pictogram please refer to flapper on the cover



Dimensions																		
Size	Torque [Nm]		Pilot bore	Max. finish bore		Dimensions [mm]										Dowel screw (10.9)		Grease feeding [dm ³] ²⁾
	TkN	TkN (42CrMo4)		d ₁ ; d ₂	l ₁ ; l ₂	Lengthened hub max. l ₁ ; l ₂	D	DA1 ³⁾	DA2 ³⁾	LH	EH	F ¹⁾	d ₃ ¹⁾	z	M	T _A [Nm]		
10	930	1580	26	50	43	105	67	111	84			74	52	6	M6	15	0,02	
15	2000	3300	26	64	50	115	87	152	107			84	68	8	M8	36	0,04	
20	3500	6300	31	80	62	130	108	178	130			104	85	6	M10	72	0,08	
25	6500	11000	38	98	76	150	130	213	158			123	110	6	M12	125	0,12	
30	10000	17400	44,5	112	90	170	153	240	182			148	130	8	M12	125	0,18	
35	17000	28800	46	133	105	185	180	280	214			172	150	8	M14	200	0,22	
40	28500	48500	52	158	120	215	214	318	250			192	175	8	M14	200	0,35	
45	37000	62000	80	172	135	245	233	347	274			216	190	10	M14	200	0,45	
50	51000	86000	80	192	150	295	260	390	309			241	220	8	M18	430	0,70	
55	65000	110000	90	210	175	300	283	425,5	334			275	250	14	M18	430	0,90	
60	85000	145000	100	232	190	305	312	457	365,5			316	265	14	M18	430	1,15	
70	135000	240000	100	276	220	310	371	527	425			360	300	16	M20	610	1,50	
80	175000	300000	140	300	280	-	394	545	475			340	310	18	M20	610	2,50	
85	225000	380000	160	325	292	-	430	585	515			352	330	20	M20	610	3,00	
90	290000	500000	180	350	305	-	464	640	560			365	360	20	M24	1000	4,00	
100	380000	650000	220	390	330	-	512	690	612			390	400	24	M24	1000	5,00	
110	480000	820000	220	420	350	-	560	765	665			410	420	20	M30	1700	6,00	
120	620000	1050000	260	450	420	-	608	825	720			480	470	24	M30	1700	7,50	
130	-	1450000	300	500	440	-	684	950	805			520	520	20	M36	2800	9,00	
140	-	1950000	380	550	460	-	750	1020	875			570	590	24	M36	2800	12,00	
150	-	2750000	460	630	520	-	850	1140	975			630	670	30	M36	2800	15,00	

■ = Standard

¹⁾ Space required to align the coupling or replace the sealing ring

²⁾ Grease feeding for each coupling half

³⁾ For dimension type F see page 100. For type D see page 102.

Ordering example:	GEARex® FH 10	d ₁ Ø50	d ₂ Ø50	250
	Size and type of coupling	Finish bore with keyway to DIN 6885 sheet 1	Finish bore with keyway to DIN 6885 sheet 1	Shaft distance dimension EH

Components

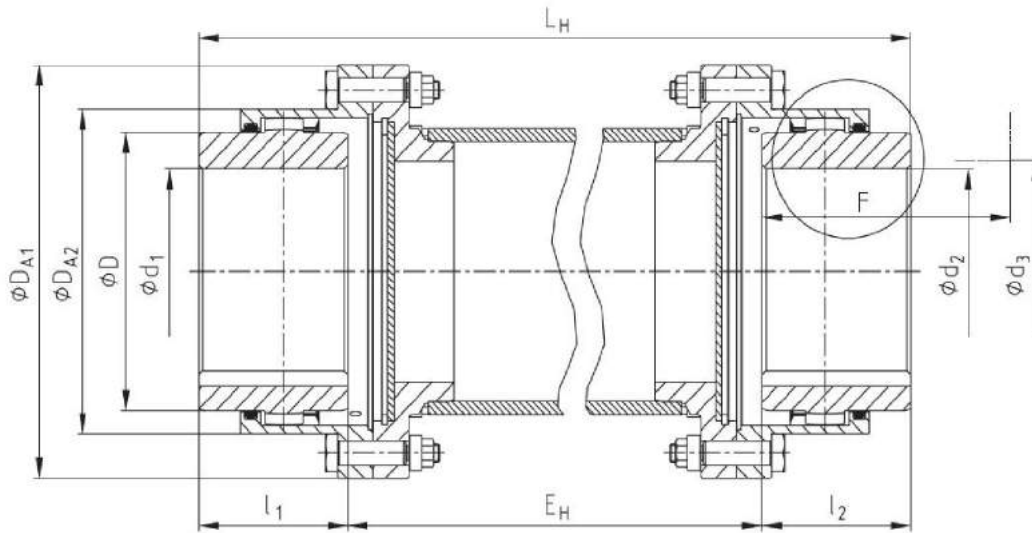

Types

Type FH

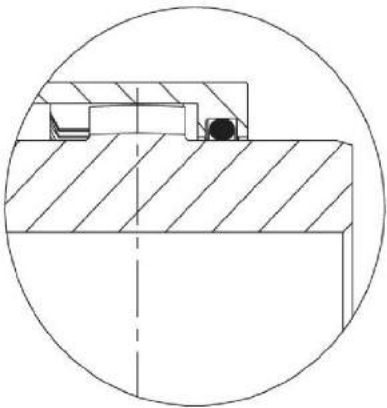

Type DH

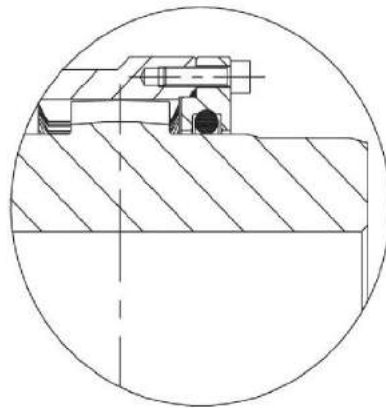

GEARex® FR and DR All-steel gear couplings

Single-cardanic, high power density

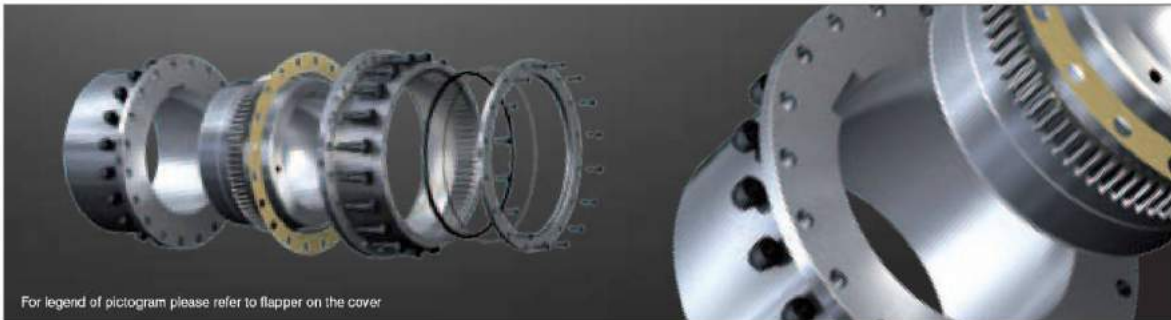

For legend of pictogram please refer to flapper on the cover

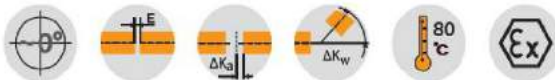

Dimensions																		
Size	Torque [Nm]		Maximum finish bore		Dimensions [mm]										Dowel screw (10.9)			Grease feeding [dm ³]
	T _{KN}	T _{KN} (42CrMo4)	d ₁	d ₄	l ₁ , l ₂	Lengthened hub max. l ₁ , l ₂	D	DA1	DA2	DF	LR	F ¹⁾	d ₃ ¹⁾	z	M	T _A [Nm]		
10	930	1580	50	60	43	105	67	111	94	84	88	74	52	6	M6	15	0,02	
15	2000	3300	64	78	50	115	87	152	107	107	103	84	68	8	M8	36	0,04	
20	3500	6300	80	95	62	130	108	178	130	130	127	104	85	6	M10	72	0,08	
25	6500	11000	98	115	76	150	130	213	158	156	157	123	110	6	M12	125	0,12	
30	10000	17400	112	135	90	170	153	240	182	182	185	148	130	8	M12	125	0,18	
35	17000	28900	133	155	105	185	180	280	214	214	216	172	150	8	M14	200	0,22	
40	28500	48500	158	185	120	215	214	318	250	250	244	192	175	8	M14	200	0,35	
45	37000	62000	172	200	135	245	233	347	274	274	276	216	190	10	M14	200	0,45	
50	51000	86000	192	225	150	295	260	390	309	309	305	241	220	8	M18	430	0,70	
55	65000	110000	210	245	175	300	283	425,5	334	334	356	275	250	14	M18	430	0,90	
60	85000	145000	232	285	190	305	312	457	365,5	365,5	388	316	285	14	M18	430	1,15	
70	135000	240000	276	310	220	310	371	527	425	425	450	360	300	16	M20	610	1,50	
80	175000	300000	300	340	280	-	394	545	475	482	570	340	310	18	M20	610	2,50	
85	225000	380000	325	370	292	-	430	585	515	500	597	352	330	20	M20	610	3,00	
90	290000	500000	350	400	305	-	464	640	560	546	623	365	360	20	M24	1000	4,00	
100	380000	650000	390	440	330	-	512	690	612	594	673	390	400	24	M24	1000	5,00	
110	480000	820000	420	480	350	-	580	765	665	647	710	410	420	20	M30	1700	6,00	
120	620000	1050000	450	520	420	-	608	825	720	700	852	480	470	24	M30	1700	7,50	
130	-	1450000	500	560	440	-	684	950	805	760	890	520	520	20	M36	2800	9,00	
140	-	1950000	550	610	460	-	750	1020	875	835	930	570	590	24	M36	2800	12,00	
150	-	2750000	630	690	520	-	850	1140	975	935	1055	630	670	30	M36	2800	15,00	

■ = Standard

¹⁾ Space required to align the coupling or replace the sealing ring

Ordering example:	GEARex® FR 10	d ₁ Ø50	d ₄ Ø60
	Size and type of coupling	Finish bore with keyway to DIN 6885 sheet 1	Finish bore with keyway to DIN 6885 sheet 1

Components

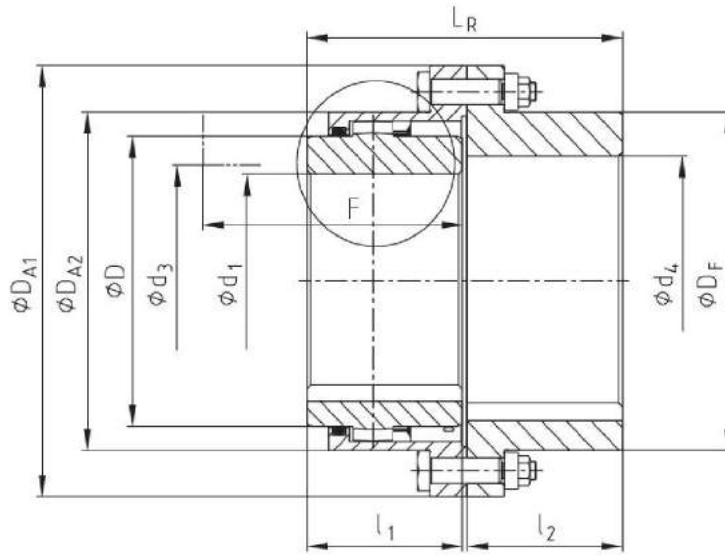

Types

Type FR

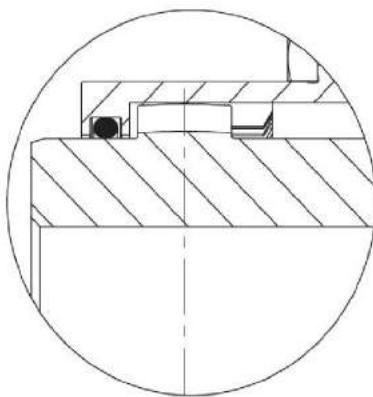

Type DR

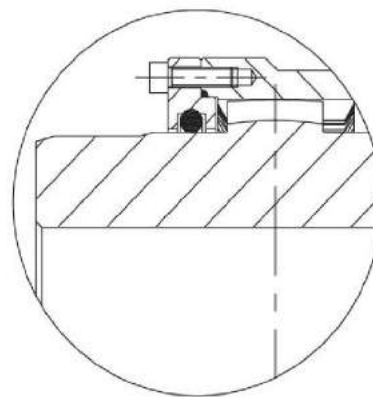

Displacements

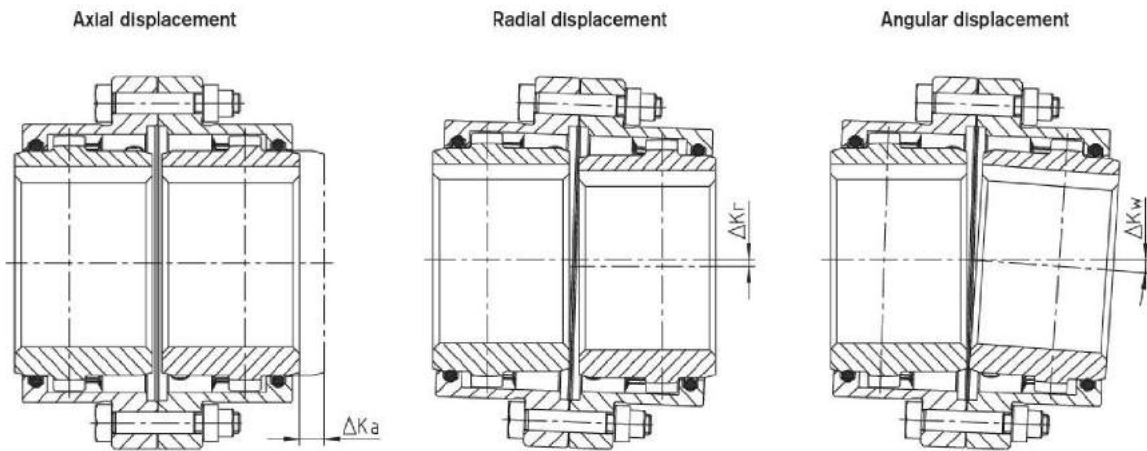

Displacements			
Size	Max. axial displacement ΔKa [mm]	Max. permissible displacements 1)	
		ΔKr [mm]	ΔKw [°]
10		± 0,4	
15		± 0,5	
20		± 0,6	
25	± 1,0	± 0,8	
30		± 1,0	
35		± 1,0	
40		± 1,2	
45		± 1,4	
50		± 1,6	
55	± 1,5	± 1,8	
60		± 2,0	0,5° per hub
70		± 2,2	
80		± 2,5	
85		± 2,8	
90	± 2,0	± 3,0	
100		± 3,2	
110		± 4,4	
120		± 5,5	
130		± 5,7	
140	± 2,5	± 6,0	
150		± 6,6	

1) The displacement figures are maximum figures which must not occur in parallel. If both radial and angular displacement arises at the same time, these figures have to be reduced (see examples of calculation and diagramme).

Example 1:
ΔKr = 30%
ΔKw = 70%

Example 2:
ΔKr = 60%
ΔKw = 40%

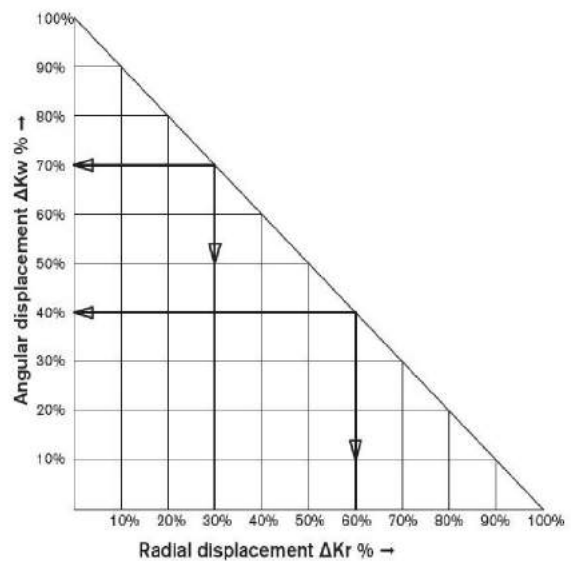

Flange dimensions in accordance with AGMA 9008-B00

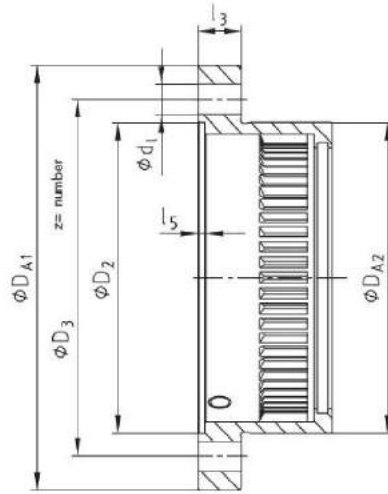

Size	Flange dimensions							
	Dimensions [mm]							
	DA1	DA2	D2	D3	d1	Number z	l3	l5
10	111	84	82	95,25	6,35	6	14	3
15	152	107	105	122,24	9,52	8	19	3
20	178	130	130	149,23	12,70	6	19	3
25	213	158	153	180,97	15,87	6	22	4
30	240	182	178	206,38	15,87	8	22	4
35	280	214	205	241,30	19,05	8	28,5	5
40	318	250	243	279,40	19,05	8	28,5	4
45	347	274	265	304,80	19,05	10	28,5	5,5
50	390	309	302	342,90	22,22	8	38	6
55	425,5	334	320	368,30	22,22	14	38	6
60	457	365,5	353	400,05	22,22	14	26	6
70	527	425	412	463,55	25,40	16	28,5	8

Other types

Type SD

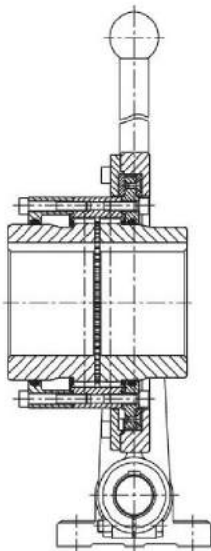

Type with brake disk

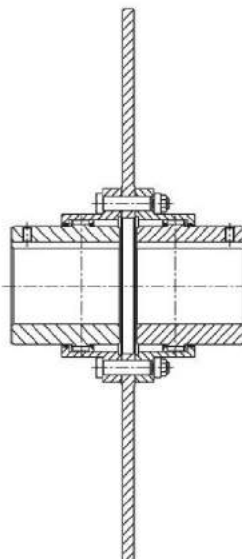

Type VD (vertical assembly)

